

**MINISTRY OF INFORMATION AND  
COMMUNICATIONS**

**DEPARTMENT OF AIR TRANSPORT**



**Renovation and Maintenance of Airport infrastructures at  
Bumthang Domestic Airport**

**NOVEMBER 2017**

## **Preface**

This Bidding Document for the Procurement of small works up to Nu. 4 million has been prepared following the Public Procurement Policy Division (PPPD) Ministry of Finance to be used for the Procurement of small works through National Competitive Bidding (NCB) in projects that are financed in whole or in part by the Royal Government of Bhutan (RGoB). It should be used in conjunction with the Procurement Rules and Regulations.

Those wishing to submit comments or questions on this Bidding Document or to obtain additional information on procurement under RGoB-financed projects may contact:

Public Procurement Policy Division (PPPD)  
Ministry of Finance  
Royal Government of Bhutan  
[pppd@mof.gov.bt](mailto:pppd@mof.gov.bt)

## Contents

<b>Section 1: Instructions to Bidder (ITB)</b> .....	<b>5</b>
<b>A. General</b> .....	<b>5</b>
1. Scope of Tender .....	5
2. Corrupt Fraudulent Collusive or Coercive Practices .....	5
3. Eligible Bidders .....	6
4. Site Visit .....	6
<b>B. Content of Bidding Document</b> .....	<b>6</b>
5. Contents of Bidding Documents.....	6
6. Clarification of Bidding Documents.....	6
7. Amendment of Bidding Documents .....	6
<b>C. Preparation of Bids</b> .....	<b>7</b>
8. One Bid per Bidder .....	7
9. Bid Preparation Costs .....	7
10. Language of Bid.....	7
11. Documents comprising the Bid.....	7
13. Alternative Bid .....	7
14. Bid Price and Discount.....	7
15. Currencies of Bid and Payment.....	8
16. Documents comprising the Technical Proposal.....	8
17. Documents establishing the Qualification of the Bidder .....	8
18. Bid Validity .....	8
20. Format and Signing of Bid.....	8
<b>D. Submission and Opening of Bids</b> .....	<b>9</b>
21. Sealing and Marking of Bids .....	9
22. Bid Submission Deadline.....	9
23. Late Bids .....	9
24. Modification, Substitution or Withdrawal of Bids.....	9
25. Bid Opening .....	9
<b>E. Tender Opening and Evaluation</b> .....	<b>10</b>
26. Confidentiality .....	10
27. Clarification .....	10
28. Bidder: Contacting the Employer .....	10
29. Determination of Responsiveness .....	10
30. Non Conformities, Errors and Omissions .....	10
31. Evaluation and Comparison of Tenders.....	11
32. Employer's Right to Accept or Reject any or all .....	11
<b>F. Contract Award</b> .....	<b>11</b>
33. Award Criteria .....	11
34. Letter of Intent to Award the Contract/ Notification of Award .....	11
35. Complaints.....	12
<b>Section 2 - Bidding Data Sheet</b> .....	<b>13</b>
<b>A. General</b> .....	<b>13</b>
<b>B. Bidding Documents</b> .....	<b>13</b>
<b>C. Preparation of Bids</b> .....	<b>13</b>
<b>D. Submission and Opening of Bids</b> .....	<b>14</b>
<b>F. Award of Contract</b> .....	<b>14</b>
<b>Section 3 – Evaluation and Qualification Criteria</b> .....	<b>15</b>
<b>Section 4: Forms of Bid &amp; Qualification Information</b> .....	<b>15</b>
<b>Standard Form: Form of bid</b> .....	<b>16</b>
<b>Standard Form: Qualification Information</b> .....	<b>17</b>

<b>Standard Form: Letter of Intent .....</b>	<b>18</b>
<b>Standard Form: Letter of Acceptance.....</b>	<b>19</b>
<b>Bank Guarantee for Bid Security.....</b>	<b>20</b>
<b>Section 5. General Conditions of Contract.....</b>	<b>21</b>
1. Definitions .....	21
2. Interpretation & Documents forming the Contract.....	21
3. Corrupt, Fraudulent, Collusive or Coercive Practices.....	22
4. Governing Language and Law .....	23
5. Engineer's Decision.....	23
6. Delegation.....	23
7. Communications and Notices .....	23
8. Sub- Contracting.....	23
9. Contractor's Personnel .....	23
10. Welfare of Labourers & Child Labour .....	23
11. Safety, Security and Protection of the Environment .....	23
12. Access to the Site .....	23
13. Documents, Information. ....	23
14. Property.....	23
15. Insurance .....	24
16. Possession of the Site .....	24
17. Commencement of Works.....	24
18. Completion of Works.....	24
19. Programme of Works .....	24
20. Early Warning.....	24
21. Compensation Events.....	24
22. Non-Scheduled Items of Works.....	24
23. Schedule of Works .....	24
24. Payment Certificates .....	24
25. Payments and Currency .....	25
26. Retention.....	25
27. Liquidated Damages .....	25
28. Performance Security.....	25
29. Price Adjustment.....	25
30. Completion.....	25
31. Correction of Defects .....	26
32. Taking Over .....	26
33. Final Account.....	26
34. Termination.....	26
35. Payment upon Termination .....	27
36. Release from Performance .....	27
37. Force Majeure .....	27
38. Settlement of Disputes.....	28
<b>Section 6. Special Conditions of Contract.....</b>	<b>29</b>
<b>Section 7 – Contract Forms .....</b>	<b>31</b>
<b>Form-1 .....</b>	<b>32</b>
<b>Form-2.....</b>	<b>33</b>
<b>Contract Agreement.....</b>	<b>33</b>
<b>Form-3.....</b>	<b>34</b>
<b>Bank Guarantee for Performance Security.....</b>	<b>34</b>
<b>Bank Guarantee for mobilisation advance .....</b>	<b>35</b>

# Section 1: Instructions to Bidder (ITB)

## A. General

1. Scope of Tender
  - 1.1 The Employer, as **indicated in the BDS** issues this Bidding Document for the procurement of Works as specified in Section 6 (Employer's requirement): The name, identification and identification of this bidding are **provided in the BDS**.
  - 1.2 The successful Bidder will be required to complete the Works within the Time for Completion stated in the Special Conditions of Contract (SCC).
  - 1.3 Throughout this Bidding Documents;
    - (a) The term "in writing means communicated in written form with proof of receipt;
    - (b) If the context so requires, singular means plural and vice versa; and
    - (c) "day" means calendar day.
2. Corrupt Fraudulent Collusive or Coercive Practices
  - 2.1 The Royal Government of Bhutan requires that Employers and the Bidders shall observe the highest standard of ethics during the implementation of procurement proceedings and the execution of Contracts under public funds.
  - 2.2 In pursuance of this requirement, the Employer shall
    - (a) exclude the bidder from participation in the procurement proceeding concerned or reject a proposal for award; and
    - (b) declare a bidder ineligible, either indefinitely or for a stated period of time, from participation in procurement proceedings under public funds;
  - 2.3 If it, at any time, determines that the bidder has engaged in corrupt, fraudulent, collusive or coercive practices in competing for, or in executing, a Contract under the public funds.
  - 2.4 The Government defines, for the purposes of this provision, the terms set forth below as follows :
    - a) "**corrupt practice**"<sup>1</sup> is the offering, giving, receiving or soliciting, directly or indirectly, of anything of value to influence improperly the actions of another party;
    - b) "**fraudulent practice**"<sup>2</sup> is any intentional act or omission including misrepresentation, that knowingly or recklessly misleads, or attempts to mislead, a party to obtain a financial or other benefits or to avoid an obligation;
    - c) "**collusive practice**"<sup>3</sup> is an arrangement between two or more parties designed to achieve an improper purpose, including to influence

---

<sup>1</sup> 'Another party' refers to a public official acting in relation to the procurement process or contract execution.

<sup>2</sup> A 'party' refers to a public official; the term 'benefit' and 'obligation' relate to the procurement process or contract execution; and the 'act or omission' is intended to influence the procurement process or contract execution.

<sup>3</sup> 'parties' refers to participations in the procurement process including public officials attempting to establish bid prices at artificial, non competitive levels.

improperly the actions of another party;

d) **“coercive practice”**<sup>4</sup> is impairing or harming or threatening to impair or harm, directly or indirectly, any party or the property of the party to influence improperly the actions of a party.

2.5 The bidder shall be aware of the provisions on fraud and corruption stated in GCC Clause 3 and GCC Sub-Clause 34.2(d).

2.6 The RGoB requires that the Employer’s personnel have an equal obligation not to solicit, ask for and/or use coercive methods to obtain personal benefits in connection with the said proceedings.

- |                     |   |
|---------------------|---|
| 3. Eligible Bidders | 3.1 Bidders of the categories <b>specified in the BDS</b> are eligible to participate in this bidding process.  |
|                     | 3.2 The Employer shall invite Bids using the Open Tendering Method (National Competitive Bidding) or limited tender as applicable.  |
|                     | 3.3 The bidder shall meet the qualification requirement stated in the BDS   |
| 4. Site Visit       | 4.1 The Bidders, at their own responsibility and risk, is encouraged to visit and examine the Site and obtain all information that may be necessary for preparing the bid and entering into a Contract for performance of the Works. The costs of visiting the Site shall be at the bidder’s own expense. |

## B. Content of Bidding Document

- |                                  |  |
|----------------------------------|--|
| 5. Contents of Bidding Documents | 5.1 The sections comprising the Bidding Document are listed below and should be read in conjunction with any Amendment issued in accordance with ITB Clause 7: |
|----------------------------------|--|

### **PART 1 Bidding Procedures**

- Section 1: Instructions to Bidders (ITB)
- Section 2: Bidding Data Sheet (BDS)
- Section 3: Evaluation and Qualification Criteria
- Section 4: Bidding forms
- Section 5: General Conditions of Contract (GCC)
- Section 6: Special Conditions of Contract (SCC)
- Section 7: Contract Forms
- Section 8: Bill of Quantities & Specifications
- Section 9: Drawings

5.2 The Employer is not responsible for the completeness of the Bidding Document and their Addenda, if they were not obtained directly from the source stated by the Employer in the Invitation for Bids.

5.3 The Bidder is expected to examine all instructions, forms terms, and specifications in the Bidding Documents. Failure to furnish all information or documentation required by the Bidding Documents may result in the rejection of the bid.

- |                                       |  |
|---------------------------------------|--|
| 6. Clarification of Bidding Documents | 6.1 A prospective Bidder requiring any clarification of the Bidding Document shall contact the Employer in writing at the Employer’s address <b>indicated in the BDS</b> .   |
| 7. Amendment of Bidding               | 7.1 At any time prior to the deadline for submission of Bid, the Employer may amend the Bidding Document by issuing addenda and extend the deadline for the submission of bids at its discretion. Any amendment issued shall |

---

<sup>4</sup> A ‘party’ refers to a participant in the procurement in the procurement process or contract execution.

Documents become an integral part of the Bidding Document and shall be communicated in writing to all those who have purchased the Bidding Document.

## C. Preparation of Bids

8. One Bid per Bidder 8.1 A Bidder shall submit only one (1) Bid. A Bidder who submits or participates in more than one (1) Bid shall cause all the proposals with the Bidder's participation to be disqualified.
9. Bid Preparation Costs 9.1 The Bidder shall bear all costs associated with the preparation and submission of its Bids, and the Employer shall in no case be responsible or liable for those costs, regardless of the conduct or outcome of the Bidding process.
10. Language of Bid 10.1 All documents relating to the Bid shall be in the language specified in the BDS.
11. Documents comprising the Bid 11.1 The original and copy(ies) of Bid submitted by the Bidder shall comprise the following:
- (a) The Bid form (in the format indicated in Section IV – Forms of Bid, Qualification Information, Letter of Acceptance, and Contract);
  - (b) License and certificate
  - (c) Bid Security in accordance with Clause 19;
  - (d) Priced Bill of Quantities;
  - (e) and any other materials required to be completed and submitted by Bidders, as specified in the BDS.
- 11.2 The Instruction to Bidders, Bidding Data Sheet, General Conditions of Contract, Special Conditions of Contract, Specifications and drawings are for the information of the bidders and is not required to be submitted by the bidder,
- 12 Letter of Bid and Schedule 12.1 The letter of Bid, Schedules, and all documents listed under Clause 11, shall be prepared using the relevant forms in Section 4 (Bidding Forms), if so provided in BDS. The forms must be completed without any alterations to the text, and no substitutes shall be accepted. All blank spaces shall be filled in with the information requested.
13. Alternative Bid 13.1 Alternative Bid shall not be considered in small works.
14. Bid Price and Discount 14.1 The prices and discounts quoted by the Bidder in the Letter of Bid and in the Schedules shall confirm to the requirements specified below;
- 14.2 The bidder shall submit a bid for the whole of the works described in ITB 1.1 by filling in prices for all items of the Works, as identified in Section 4, Bidding Forms. In case of admeasurements contracts, the Bidder shall fill in rates and prices for all items of the Works described in the Bill of Quantities. Items against which no rate or price is entered by the Bidder will not be paid for by the Employer when executed and shall be deemed covered by the rates for other items and prices in the Bill of Quantities.
- 14.3 The Bid price shall take into account the cost of materials, transportation, labour, taxes, levies, overheads and profit and any other cost. The Bid price shall be fixed for the duration of performance of the Contract and shall not be subject to any adjustment on any account. The Bid price shall

be applicable for the whole works described in the Drawings, Specifications and Schedule of Works.

- |    |  |      |   |
|----|--|------|---|
| 15 | Currencies of Bid and Payment                          | 15.1 | All prices shall be quoted in Bhutanese Ngultrum (BTN) and shall be paid in BTN.  |
| 16 | Documents comprising the Technical Proposal            | 16.1 | The bidder shall furnish a work plan in simple bar chart and other information if provided in BDS, to demonstrate the adequacy of the Bidders' proposal to meet the work requirements and the completion time.  |
| 17 | Documents establishing the Qualification of the Bidder | 17.1 | To establish its qualification to perform the Contract in accordance with Section 3 (Evaluation and Qualification Criteria) the Bidder shall provide the information requested in the corresponding information sheets included in Section 4 (Bidding Forms)  |
| 18 | Bid Validity   | 18.1 | Bids shall remain valid for the period <b>specified in the BDS</b> . Any Bids which does not meet the validity requirement as per the BDS shall be rejected by the Employer as non-responsive.  |
| 19 | Bid Security   | 19.1 | The Bidder shall at their option furnish, as part of the Bid, a Bid Security as <b>specified in the BDS</b> issued by any reputed Financial Institutions in Bhutan and shall be valid thirty (30) days beyond the Bid validity period. <ul style="list-style-type: none"><li>a) Unconditional Bank Guarantee;</li><li>b) A demand Draft; or</li><li>c) Cash Warrant</li></ul>   |
|    |  | 19.2 | In exceptional circumstances, prior to the expiration of the Bid validity period, the Employer may solicit the Bidder's consent to an extension of the Bid validity period. The request and responses shall be made in writing. The validity of Bid Security shall be suitably extended promptly.   |
|    |  | 19.3 | The Bid Security may be forfeited: <ul style="list-style-type: none"><li>(a) if the Bidder withdraws the Bid after Bid opening during the period of Bid validity. Further the bidder may be excluded from future participation for a period of two years.</li><li>(b) if the Bidder does not accept the correction of the Bid price, pursuant to clause 31; or</li><li>(c) in the case of a successful Bidder, if the Bidder fails within the specified time limit to sign the Agreement; or furnish the required Performance Security.</li></ul> |
| 20 | Format and Signing of Bid                              | 20.1 | The Bidder shall prepare one (1) original of the documents comprising the Bid as described in ITB Clause 11 and clearly mark it "ORIGINAL." In addition, the Bidder shall prepare the number of copies of the Bid, as specified in the BDS and clearly mark each of them "COPY." In the event of any discrepancy between the original and the copies, the original shall prevail.   |
|    |  | 20.2 | The original and each copy of the Bid shall be typed or written in indelible ink and shall be signed by the person duly authorized to sign on behalf of the Bidder.   |
|    |  | 20.3 | Any interlineations, erasures, or overwriting shall be valid only if they are signed or initialled by the person(s) signing the Bid.  |



## D. Submission and Opening of Bids

- 21 Sealing and Marking of Bids
- 21.1 The Bidder shall enclose the original in one (1) envelope and all the copies of the bid in another envelope, duly marking the envelopes as "ORIGINAL" and "COPY." These two (2) envelopes shall then be enclosed in one (1) single outer envelope.
- 21.2 The inner envelopes shall:
- (a) Be signed across the seals by the person authorised to sign the Bid on behalf of the Bidder;
  - (b) Be marked "ORIGINAL" and "COPY" and
  - (c) Bear the name and address of the Bidder.
- 21.3 The outer envelope shall;
- (a) Be sealed with adhesive or other sealant to prevent reopening;
- 21.4 be addressed to the Employer at the address specified in the BDS; bear a statement "DO NOT OPEN BEFORE....." the time and date for Bid opening as specified in the BDS.
- 21.5 If all or any envelopes are not sealed and marked as required by ITB Sub-Clause 21, the Employer **shall not reject the bids but assume no responsibility for the misplacement or premature opening of the Bid.**
- 22 Bid Submission Deadline
- 22.1 Bids must be received by the Employer at the address and no later than the date and time **specified in the BDS.**
- 22.2 Bids may be hand delivered, posted by registered mail or sent by courier.
- 22.2 The Employer may, at its discretion, extend the deadline for the submission of Bids by amending the Bidding Document in accordance with ITB Clause 7, in which case all rights and obligations of the Employer and Bidders previously subject to the deadline shall thereafter be subject to the new deadline as extended.
- 23 Late Bids
- 23.1 Late bids shall not be considered and shall be returned unopened
- 24 Modification, Substitution or Withdrawal of Bids
- 24.1 A Bidder may modify, substitute or withdraw their Bids after it has been submitted by sending a written notice before the deadline for submission of Bids.
- 25 Bid Opening
- 25.1 The Employer shall open the Bids in the presence of the bidders who is attending the bid opening, including modifications or substitutions made pursuant to ITB Clause 24. Bidders or their representatives shall be allowed to attend and witness the bid opening and shall sign a register evidencing their attendance.
- 25.2 The name of the Bidder, Bid modifications, substitutions or withdrawals, total amount of each Bid, number of corrections, discounts, and the presence or absence of requisite Bid Security, and such other details as the Employer, at its discretion, may consider appropriate, shall be read out aloud and recorded.
- 25.3 The Employer shall prepare minutes of the Bid opening. The minutes shall include, as a minimum, the name of the Bidders and whether there has been a withdrawal, substitution or modification; the Bid Price including any discounts and the presence or absence of a Bid Security, if one was required.

- 25.4 Bids not opened and read out at the Bid opening shall not be considered, irrespective of the circumstances, and shall be returned unopened to the Bidder.

## **E. Tender Opening and Evaluation**

- 26 Confidentiality 26.1 After the opening of Bids, information relating to the examination, clarification, and evaluation of Bids and recommendations for award shall not be disclosed to Bidders or other persons not officially concerned with the evaluation process until after the award of the Contract is announced.
- 27 Clarification 27.1 The Employer may ask Bidders for clarification of their Bids in order to facilitate the examination and evaluation of Bids. The request for clarification and the response shall be in writing, and any changes in the prices or substance of the Bid shall not be sought, offered or permitted, except to confirm the correction of arithmetical errors discovered by the Employer in the evaluation of the Bids, in accordance with ITB Clause 31.
- 28 Bidder:  
Contacting the  
Employer 28.1 Following the opening of Bids and until the Contract is signed no Bidder shall make any unsolicited communication to the Employer or try in any way to influence the Employer's examination and evaluation of Bids which may result in the rejection of bids. If any Bidder wishes to contact the Employer on any matter related to the Bidding process, it should do so in writing
- 29 Determination  
of  
Responsiveness 29.1 Prior to detailed evaluation of bids, the employer shall determine whether each bid (a) meets the eligibility criteria defined in ITB clause 3; (b) has been properly signed; (c) is accompanied by the bid security; and (d) is substantially responsive to the requirements of the bidding documents.
- 29.2 A substantially responsive Bid is one that conforms in all respects to the requirements of the Bidding Document without material deviation, reservation or omission. A material deviation, reservation or omission is one that:
- (a) affects in any substantial way the scope, quality, or performance of the Works specified in the Contract; or
  - (b) limits in any substantial way, or is inconsistent with the Bid Document, the Employer's rights or the Bidder's obligations under the Contract; or
  - (c) if rectified would unfairly affect the competitive position of other Bidders presenting substantially responsive Bids.
- 29.3 If a Bid is not substantially responsive to the Bidding Document it shall be rejected by the Employer and shall not subsequently be made responsive by the Bidder by correction of the material deviation, reservation or omission.
- 29.4 There shall be no requirement as to the minimum number of responsive Bids.
- 30 Non  
Conformities, 30.1 The Employer may regard a Bid as responsive even if it contains minor deviations that do not materially alter or depart from the characteristics,

Errors and Omissions		terms, conditions and other requirement set forth in the Bidding Document or if it contains errors or oversights that are capable of being corrected without affecting the substance of the Bid.
31 Evaluation and Comparison of Tenders	31.1	The Employer shall evaluate and compare only those Bids determined to be substantially responsive to the requirements of the Bidding Document. Substantially responsive Bids are those which fulfil the requirements of ITB Clauses 11 and 12.
	31.2	The evaluation will take into account corrected Bid Price and discounts (if any).
	31.3	The Employer will check substantially responsive Bids for any arithmetical errors. Where there is a discrepancy between the amounts in figures and words, the amount in words will govern. If a Bidder refuses to accept the correction, its Bids shall be rejected. The Employer shall correct arithmetical errors on the following basis:  (a) if there is a discrepancy between the unit price and the line item total, the unit price shall prevail and the total price shall be corrected, unless in the opinion of the Employer there is an obvious misplacement of the decimal point in the unit price, in which case the total price, as quoted, shall govern and the unit price shall be corrected; and
32. Employer's Right to Accept or Reject any or all	32.1	The Employer reserves the right to accept any Bid, to annul the Bid proceedings, or to reject any or all Bids, at any time prior to Contract award, without thereby incurring any liability to Bidders, or any obligation to inform Bidders of the grounds for the Employer's actions.

## F. Contract Award

33. Award Criteria	33.1	The Employer shall award the Contract to the Bidders whose offer is substantially responsive to the Bidding Document and that has been determined to be the lowest evaluated Bid, provided that the Bidder is determined to be qualified to perform the Contract satisfactorily
34. Letter of Intent to Award the Contract/ Notification of Award	34.1	The Employer shall notify the concerned Bidder whose bid has been selected in accordance with ITB 33.1 in writing (in the format in Section 4-hereafter called the "Letter of Intent to Award") that the Employer has intention to accept its bid and the information regarding the name, address and amount of selected bidder shall be given to all other bidders who submitted the bid. Such notification should be communicated in writing, including by cable, facsimile, telex or electronic mail to all the bidders on the same day of dispatch. The Employer shall ensure that the same information is uploaded on their website on the same day of dispatch.
	34.2	If no bidder submits an application pursuant to ITB 35 within a period of ten (10) days of the notice provided under ITB 34.1, Prior to the expiration of the period of Bid validity, the Employer shall notify the successful Bidder, in writing that its Bid has been accepted. Until a formal contract is prepared and executed, the Notification of Award shall constitute a binding Contract.
	34.3	Within fifteen (15) working days of the receipt of the Notification of Award from the Employer, the successful Bidder shall furnish the Performance Security, in the amount specified in the BDS.
	34.4	The proceeds of the performance security shall be payable to the Employer unconditionally upon first written demand as compensation for any loss resulting from the Contractor's failure to complete its obligations under the

### Contract

- 34.5 Within fifteen (15) working days of receipt of the notification of award, the successful Bidder shall sign, date and return it to the Employer.

### 35.Complaints

- 35.1 The Bidder shall submit the complaint in writing within ten (10) days from the date of letter of intent to award the contract pursuant to ITB 34.1 to the Employer.
- 35.2 The Bidder may appeal to the Independent Review Body only if the Employer has not delivered the decision within the specified time, or the complainant is not satisfied with the decision of the Employer in accordance with rules and procedures of Independent Review Body.

<b>Section 2 - Bidding Data Sheet</b>	
<b>ITB Clause</b>	<b>Amendment of, and Supplements to, Clauses in the Instructions to Bidders</b>
<b>A. General</b>	
<b>ITB 1.1</b>	<p>The Employer is [<i>Director, Department of Air Transport</i>]</p> <p>The Name and Identification of the Contract is/are [ <i>Renovation and maintenance of airport infrastructures at Bumthang Domestic Airport</i>]</p> <p>The Works are [ <i>Renovation and maintenance of airport infrastructures at Bumthang Domestic Airport</i>]</p>
<b>ITB 3.2</b>	<p><b>Option: Open Tendering method</b></p> <p>All Bidders regardless of whether enlisted or not enlisted with the Dzongkhag may submit Bids provided they otherwise qualify.</p>
<b>ITB 3.3</b>	<p>The evaluation shall be based on the lowest price of the responsive bidder and the work will be awarded to the lowest responsive bidder.</p>
<b>ITB 4.1</b>	<p>The Bidders, at their own responsibility and risk, is encouraged to visit and examine the Site and obtain all information that may be necessary for preparing the bid and entering into a Contract for performance of the Works. The costs of visiting the Site shall be at the bidder's own expense. The department will not be accepting bid from the bidders who did not visit the site. The deadline for site visit is 26<sup>th</sup> December 2017 and the site visit should be made along with the Airport Management, Bumthang Domestic Airport. The record of site visit shall be maintained by the Airport Management.</p>
<b>B. Bidding Documents</b>	
<b>ITB 7.1</b>	<p>For <b><u>clarification of Tenders purposes</u></b> only, the Employer's address is:</p> <p>Attention: [Jamyang T Dorji/Tashi Gyeltshen]</p> <p>Address: [Airport Development Division, DoAT]</p> <p>Telephone: [+975-08-272168]</p> <p>Electronic mail address: [jtdorji@doat.gov.bt or tgyeltshen@doat.gov.bt]</p>
<b>C. Preparation of Bids</b>	
<b>ITB 15.1</b>	<p>The Bid validity period shall be [ 90 ] days.</p>
<b>ITB 15.2</b>	<p>A Bid Security in the amount of Nu. 24,000.00 (Nu. Twenty four thousand) only will be required, in the form;</p> <ul style="list-style-type: none"> <li>a) Unconditional Bank guarantee</li> <li>b) Cash warrant; or</li> <li>c) Demand draft</li> </ul>
<b>ITB 16.1</b>	<p>A simple bar chart is <i>required</i></p>

<b>ITB 19.1</b>	In addition to the original, [one] copy of the bid shall be submitted.
<b>D. Submission and Opening of Bids</b>	
<b>ITB 17.2</b>	The inner and outer envelopes shall bear the following additional identification marks: <i>[The outer envelope shall bear the name of tender and shall mark as 'Do Not Open Before 29<sup>th</sup> 12/17, 2:30pm'. The inner envelope shall indicate Original and Copy both bearing the name of contract sealed and signed.]</i>
<b>ITB 17.2</b>	For <b><u>Bid submission purposes</u></b> only, the Employer's address is: Attention: Director Address: Department of Air Transport The deadline for the submission of Tenders is: 29 <sup>th</sup> December 2017 Time & Date: Before 12 noon on 29 <sup>th</sup> December 2017.
<b>ITB 21.1</b>	The Bid opening shall take place on the same day as the closing day of the bid submission at: <i>[Engineering Cell, Airport Development Division, Arrival Terminal (Second Floor)]</i> Date: <i>[29<sup>th</sup> December 2017]</i> ; Time: <i>[2:30PM]</i>
<b>F. Award of Contract</b>	
<b>ITB 34.2</b>	The amount of Performance Security shall be [10] percent of the Contract Price.

### **Section 3 – Evaluation and Qualification Criteria**

This section contains all the criteria that the Employer shall use to evaluate bids and qualify Bidders if the bidding was not preceded by a prequalification exercise and post qualifications are applied. Procuring Agency may apply basic minimum technical qualification requirement (manpower and equipments) only if there is a project specific need.

#### **1. Evaluation**

1.1 Evaluation shall be done to determine the responsiveness and the award shall be made to the lowest evaluated bidder.

### **Section 4: Forms of Bid & Qualification Information**

**Table of Standard**

#### **Forms**

Standard Form: Form of Bid

Standard Form: Letter of Intent

Standard Form: Letter of Acceptance

Standard Form: Bid security Bank Guarantee

# Standard Form: Form of bid

*Notes on Form of Bid:*

*The Bidder shall fill in and submit this bid form with the Bid. If Bidders do not fill in the Contract Price and does not sign this Bid form, the bids will be rejected..*

\_\_\_\_\_ [date]

To \_\_\_\_\_

Address \_\_\_\_\_

\_\_\_\_\_

\_\_\_\_\_

We offer to execute the contract for “Maintenance of Damaged Perimeter Fence, Providing Electric fence and street light at Gelephu Domestic Airport” in accordance with the Conditions of Contract accompanying this Bid for the Contract Price of \_\_\_\_\_ [amount in figures] ( \_\_\_\_\_ ) [amount in words] \_\_\_\_\_ [name of currency].

The contract shall be paid in Ngultrums (Nu.)

This Bid and your written acceptance of it shall constitute a binding Contract between us. We understand that you are not bound to accept the lowest or any Bid you receive.

We hereby confirm that this Bid complies with the Bid validity and Bid Security required by the bidding documents and specified in the Bidding Data.

Authorized Signature: \_\_\_\_\_

**(Affix Legal Stamp)**

Name and Title of Signatory: \_\_\_\_\_

Name of Bidder: \_\_\_\_\_

Address: \_\_\_\_\_



# Standard Form: Qualification Information

*Notes on Form of Qualification Information: The following information is to be filled in by bidders which will be used for purposes of evaluation*

## 1. Individual bidders

1.1 Constitution of legal status of Bidder [attach copy]

Place of registration: \_\_\_\_\_

Principal place of business: \_\_\_\_\_

Power of attorney of signatory of Bid [attach]

1.2 Qualifications and experience of key personnel proposed for administration and execution of the Contract. Refer BDS. The supporting documents such detailed CVs signed in original supported by certificates for qualification and experience.

Position	Name	Qualification & year of experience (general)	Year of experience in proposed position	Remarks
Not Applicable				

# Standard Form: Letter of Intent

*(Letterhead paper of the Employer)*

## **Notes on standard form of letter of Intent**

*This issuance of Letter of Intent (always before letter of acceptance) is the information of the selection of the bid of the successful bidder by the Employer and for providing information to other unsuccessful bidders who participated in the bid as regards the outcome of the procurement process*

*The Employer shall allow 10 days as described in ITB 34.2 between this letter of intent and letter of acceptance to allow aggrieved bidders to challenge your decision if they feel they have treated unfairly.*

*(Insert date)*

To:-----[Name and address of the Contractor]

This is to notify you that, it is our intention to award the contract for your Bid dated-----  
[Insert date] for execution of the-----  
-----[Insert name of the contract and identification number, as given in the BDS/SCC] for the  
Contract Price of-----  
-----[Insert amount in figure and words and name of currency] as corrected and modified[if any  
corrections] in accordance with the Instructions to Bidders.

Authorized Signature: -----

Name and Title of Signatory:-----

Name of Agency:-----

CC:

[Insert name and address of all other bidders who submitted the bid]

# Standard Form: Letter of Acceptance

[Letter head paper of the Employer]

*Notes on Standard Form of Letter of Acceptance*

*The Letter of Acceptance will be the basis for formation of the Contract as described in Clauses 31 and 32 of the Instructions to Bidders. This Standard Form of Letter of Acceptance should be filled in and sent to the successful Bidder only after evaluation of bids has been completed.*

[date] \_\_\_\_\_

To: \_\_\_\_\_

[name of the Contractor]

\_\_\_\_\_  
[address of the Contractor]

This is to notify that your Bid dated \_\_\_\_\_ for the execution of the contract for the construction of “\_\_\_\_\_ - \_\_\_\_\_” for the Contract Price \_\_\_\_\_ [amount in numbers] \_\_\_\_\_ [amount in words] \_\_\_\_\_ [name of currency], as corrected and modified in accordance with the Instructions to Bidders is hereby accepted by our Agency. The start date of the project is \_\_\_\_\_. The completion date for whole of the works shall be \_\_\_\_\_.

You are hereby instructed to proceed with the execution of the said Works in accordance with the Contract documents.

Authorized Signature:

\_\_\_\_\_

Name and Title of Signatory: \_\_\_\_\_

Name of Agency:

\_\_\_\_\_

Attachment: Agreement

# Bank Guarantee for Bid Security

*[this is the format for the Bid Security to be issued by a financial institutions in Bhutan in accordance with ITB Clause 19]*

Invitation for Bid No:

Date:

Bid Package No:

To:

[Name and address of Employer]

## TENDER GUARANTEE No:

We have been informed that *[name of Bidder]* (hereinafter called "the Bidder") intends to submit to you its Bid dated *[date of bid]* (hereinafter called "the Tender") for the execution of the Works of *[description of works]* under the above Invitation for Bids (hereinafter called "the IFB").

Furthermore, we understand that, according to your conditions Bids must be supported by a Bid Guarantee.

At the request of the Bidder, we *[name of bank]* hereby irrevocably undertake to pay you, without cavil or argument, any sum or sums not exceeding in total an amount of Nu *[insert amount in figures and words]* upon receipt by us of your first written demand accompanied by a written statement that the Bidder is in breach of its obligation(s) under the Bid conditions, because the Bidder:

- (a) has withdrawn its Bids during the period of Bid validity specified by the Bidder in the Form of Bid; or
- (b) does not accept the correction of errors in accordance with the Instructions to Bidders ITB; or
- (c) having been notified of the acceptance of the Bid by the Employer during the period of Bid validity,
  - (i) fails or refuses to furnish the performance security in accordance with the ITT, or
  - (ii) fails or refuses to execute the Contract Form,

This guarantee will expire

- (a) if the Bidder is the successful Bidder, upon our receipt of a copy of the Performance Security and a copy of the Contract signed by the Bidder as issued by you; or
- (b) if the Bidder is not the successful Bidder, thirty days after the expiration of the Bidder's Tender validity period, being *[date of expiration of the Tender]*.

Consequently, we must receive at the above-mentioned office any demand for payment under this guarantee on or before that date.

Signature

Signature

## Section 5. General Conditions of Contract

1. Definitions
  - 1.1 The following words and expressions shall have the meaning hereby assigned to them. Boldface type is used to identify the defined terms:
    - (a) **Completion Certificate** means the Certificate issued by the Employer as evidence that the Contractor has executed the Works in all respects as per drawing, specifications, and Conditions of Contract.
    - (b) The **Completion Date** is the date of completion of the Works as certified by the Engineer, in accordance with GCC Clause 18.
    - (c) **Contract** means the Agreement entered into between the Employer and the Contractor to execute, complete and maintain the Works.
    - (d) **Contractor** means the person or corporate body whose Tender to carry out the Works has been accepted by the Employer and is named as such in the SCC.
    - (e) **Contract Price** is the price stated in the Letter of Acceptance and thereafter as adjusted in accordance with the provisions of the Contract. The **Contractor's Bid** is the completed Bid Document including the priced offer submitted by the Contractor to the Employer.
    - (f) **Days** mean calendar days.
    - (g) A **Defect** is any part of the Works not completed in accordance with the Contract.
    - (h) The **Employer** is the party named in the SCC who employs the Contractor to carry out the Works.
    - (i) The **Engineer** is the person named in the SCC, who is responsible for supervising the execution of the works and administering the Contract.
    - (j) The **Intended Completion Date** is the date specified in the SCC on which the Contractor shall complete the Works and may be revised if extension of time or an acceleration order is issued by the Engineer.
    - (k) The **Site** is the area defined as such in the SCC.
    - (l) The **Works** are what the Contract requires the Contractor to construct, install, and hand over to the Employer, as defined in the SCC.
2. Interpretation & Documents forming the Contract
  - 2.1 In interpreting the GCC, singular also means plural, male also means female or neuter, and the other way around. Headings in the GCC shall not be deemed part thereof or be taken into consideration in the interpretation or construance of the Contract. Words have their normal meaning under the language of the Contract unless specifically defined.
  - 2.2 The following documents forming the Contract shall be interpreted in the following order of priority:
    - (a) the signed Contract Agreement.
    - (b) the letter of Notification of Award.
    - (c) the completed Bid form as submitted by the Bidder.
    - (d) the Special Conditions of Contract.
    - (e) the General Conditions of Contract.

- (f) Specifications
- (g) the Drawings.
- (h) any other document listed in the PCC as forming part of the Contract.

3. Corrupt, Fraudulent, Collusive or Coercive Practices

3.1 The Government requires that Employers, as well as Contractors shall observe the highest standard of ethics during the implementation of procurement proceedings and the execution of Contracts under public funds.

3.2 In pursuance of this requirement, the Employer shall

- (a) exclude the Contractor from participation in the procurement proceedings concerned or reject a proposal for award; and
- (b) declare a Contractor ineligible, either indefinitely or for a stated period of time, from participation in procurement proceedings under public fund;

3.3 The Government defines, for the purposes of this provision, the terms set forth below as follows:

- (a) corrupt practice<sup>5</sup> is the offering, giving, receiving or soliciting, directly or indirectly, of anything of value<sup>6</sup> to influence improperly the actions of another party;
- (b) "fraudulent practice"<sup>7</sup> is any intentional act or omission, including a misrepresentation, that knowingly or recklessly misleads, or attempts to mislead, a party to obtain a financial or other benefit or to avoid an obligation;
- (c) "collusive practice"<sup>8</sup> is an arrangement between two or more parties designed to achieve an improper purpose, including to influence improperly the actions of another party; and
- (d) "coercive practice"<sup>9</sup> is impairing or harming, or threatening to impair or harm, directly or indirectly, any party or the property of the party to influence improperly the actions of a party.

3.4 The Government requires that the Client's personnel have an equal obligation not to solicit, ask for and/or use coercive methods to obtain personal benefits in connection with the said proceedings.

---

<sup>5</sup> "another party" refers to a public official acting in relation to the procurement process or contract execution. In this context, "public official" includes staff and employees of any organizations (including any institutions providing finance for the Works) taking or reviewing procurement decisions.

<sup>6</sup> "anything of value" includes, but is not limited to, any gift, loan, fee, commission, valuable security or other asset or interest in an asset; any office, employment or contract; any payment, discharge or liquidation of any loan, obligation or other liability whatsoever, whether in whole or in part; any other services, favour or advantage, including protection from any penalty or disability incurred or apprehended or from any action or proceeding of a disciplinary or penal nature, whether or not already instituted and including the exercise or the forbearance from the exercise of any right or any official power or duty.

<sup>7</sup> a "party" refers to a public official; the terms "benefit" and "obligation" relate to the procurement process or contract execution; and the "act or omission" is intended to influence the procurement process or contract execution.

<sup>8</sup> "parties" refers to participants in the procurement process (including public officials) and an "improper purpose" includes attempting to establish bid prices at artificial, non competitive levels.

<sup>9</sup> a "party" refers to a participant in the procurement process or contract execution.

- |  |   |
|--|---|
| 4. Governing Language and Law                          | 4.1 The Contract as well as all correspondence and documents relating to the Contract exchanged by the Contractor and the Employer, shall be written in English unless otherwise stated in the SCC. The Contract shall be governed by and interpreted in accordance with the laws of the Kingdom of Bhutan.   |
| 5. Engineer's Decision                                 | 5.1 Except where otherwise specifically stated in the SCC, the Engineer will decide Contractual matters between the Employer and the Contractor in the role as representative of the Employer.  |
| 6. Delegation  | 6.1 The Engineer may delegate any of his duties and responsibilities to his representative, after notifying the Contractor, and may cancel any delegation, without retroactivity, after notifying the Contractor.   |
| 7. Communications and Notices                          | 7.1 Communications between Parties pursuant to the Contract shall be in writing to the address specified in the SCC. A notice shall be effective when delivered or on the notice's effective date, whichever is later.  |
| 8. Sub- Contracting                                    | 8.1 The Contractor shall not be permitted to subcontract any part of the Works in whole or in part.   |
| 9. Contractor's Personnel                              | 9.1 The Contractor shall employ the key personnel named in the Schedule of Key Personnel, as referred to in the SCC, to carry out the functions stated in the Schedule, or other personnel approved by the Engineer.  |
| 10. Welfare of Labourers & Child Labour                | <p>10.1 The Contractor shall provide proper accommodation to his labourers and arrange proper water supply, conservancy and sanitation arrangements at the site in accordance with relevant regulations, rules and orders of the government.</p> <p>10.2 The Contractor shall comply with the applicable minimum age, labour laws and requirements of (including applicable treaties which have been ratified by) the Government of Bhutan regarding hazardous forms of child labour.</p>   |
| 11. Safety, Security and Protection of the Environment | <p>11.1 The Contractor shall throughout the execution and completion of the Works and the remedying of any defects therein :</p> <p>(a) have full regard for the safety of all persons entitled to be upon the Site and keep the Site and the Works in an orderly state;</p> <p>(b) provide and maintain at the Contractors own cost all lights, guards, fencing, warning signs and watching for the protection of the Works or for the safety on-site; and</p> <p>(c) take all reasonable steps to protect the environment on and off the Site and to avoid damage or nuisance to persons or to property of the public or others resulting from pollution, noise or other causes arising as a consequence of the Contractors methods of operation.</p> |
| 12. Access to the Site                                 | 12.1 The Contractor shall allow the Engineer and any person authorised by the Engineer access to the Site and to any place where work in connection with the Contract is being carried out or is intended to be carried out.  |
| 13. Documents, Information.                            | 13.1 The Contractor shall furnish to the Engineer all information, schedules, calculations and supporting documentation that may be requested of it.  |
| 14. Property   | 14.1 If the contract is terminated by the Employer because of the contractors default, then, the contractor shall not be allowed to remove any materials on the Site, Plant, and Temporary Works until the matter is amicably resolved.   |

15. Insurance	15.1	The Contractor shall provide insurance as stated in the SCC
	15.2	The Contractor shall deliver policies and certificates of insurance to the Engineer, for the Engineer's approval, before the Start Date.
	15.3	If the Contractor does not provide any of the policies and certificates required, the Employer may effect the insurance which the Contractor should have provided and recover the premiums the Employer has paid from payments otherwise due to the Contractor or, if no payment is due, the payment of the premiums shall be a debt due.
16. Possession of the Site	16.1	The Employer shall give possession of the Site, or parts of the Site, to the Contractor on the date(s) specified in the SCC.
17. Commencement of Works	17.1	The Contractor may commence execution of the Works on the Start Date, or other such date as specified in the SCC, and shall carry out the Works in an expeditious manner.
	17.2	If the Contractor fails to commence the works within the above stated period, the Employer may, at his sole discretion, terminate the Contract and forfeit the Performance Security, if any.
18. Completion of Works	18.1	The Contractor shall complete the Works within the number of days stated in the SCC from the date of commencing the Works on the Site.
19. Programme of Works	19.1	Within the time stated in the SCC, the Contractor shall submit to the Engineer for approval a work program. The Contractor shall submit to the Engineer for approval an updated Programme at intervals no longer than the period stated in the SCC.
20. Early Warning	20.1	The Contractor shall warn the Engineer at the earliest opportunity of specific likely future events or circumstances that may adversely affect the quality of the work result in increase to the Contract Price or delay in the execution of the Works.
21. Compensation Events	21.1	The following shall be Compensation Events: <ul style="list-style-type: none"> <li>(a) the Employer does not give access to the Site or part of the Site by the Site Possession Date stated in the SCC; and</li> <li>(b) if the payment is delayed pursuant to Clause 25.1.</li> </ul>
	21.2	If a Compensation Event would prevent the work being completed before the Intended Completion Date, the Intended Completion Date shall be extended, as appropriate, by the Engineer.
22. Non-Scheduled Items of Works	22.1	The Contractor shall be paid for non-scheduled items of works only when the Engineer approves such works and at the rates and in the manner stated in the SCC.
23. Schedule of Works	23.1	The Schedule of Works will contain rates for all items for the construction including temporary works, installation, testing, and commissioning work to be done by the Contractor.
	23.2	The Contractor shall be paid for the quantity of the work done at the rate in the Contract Agreement for each item.
	23.3	The Contractor shall be entirely responsible for all taxes, duties, license fees, and other such levies imposed outside and inside Bhutan.
24. Payment Certificates	24.1	The Contractor shall submit to the Engineer monthly statements of the estimated value of the work executed less the cumulative amount certified previously. The Engineer shall check the Contractor's monthly statement and certify the amount to be paid to the Contractor.



- 24.2 The value of work executed shall be determined by the Engineer.
- 24.3 The value of work executed shall comprise the value of the quantities of the items in the Schedule of Works completed.
- 24.4 The value of work executed shall include the valuation of Variations, Certified Dayworks and Compensation Events.
- 24.5 The Engineer may exclude any item certified in previous certificates or reduce the proportion of any item previously certified in any certificate in the light of later information.
25. Payments and Currency
- 25.1 The Employer shall pay the Contractor the amounts certified by the Engineer within thirty (30) days of the date of each certificate.
- 25.2 The Employer shall make Advance Payment (mobilization and secured advance) to the Contractor of the amounts and by the dates stated in the SCC against provision by the Contractor of an unconditional Bank Guarantee, (Form 4).
- 25.3 The Contractor is to use the advance payment only to pay for Equipment, Plant, Materials, and mobilisation expenses required specifically for the execution of the Contract. The Contractor shall demonstrate that the advance payment has been used in this way by submitting copies of invoices or other documents to the Employer.
- 25.4 The advance payment shall be repaid by deducting proportionate amounts from payments otherwise due to the Contractor, following the schedule of completed percentages of the Works on a payment basis. No account shall be taken of the advance payment or its repayment in assessing valuations of work done, variations, claims or any amount payable due to failure to complete the works.
26. Retention
- 26.1 The Employer shall retain from each payment due to the Contractor the proportion stated in the SCC until the completion of the whole of the Works.
- 26.2 On completion of the whole of the Works, half the total amount retained shall be repaid to the Contractor, the remaining half when the Defects Liability Period has passed and the Engineer has certified that all Defects notified by the Engineer to the Contractor before the end of this period have been corrected.
27. Liquidated Damages
- 27.1 The Contractor shall pay liquidated damages to the Employer at the rate per day stated in the SCC for each day that the Completion Date is later than the Intended Completion date for the works or for any part thereof.
28. Performance Security
- 28.1 Upon Notification of Award, a Performance Security shall be provided to the Employer in the amount and form stated in the Contract Forms (Form 3). The Performance Security shall be valid until a date thirty (30) days from the date of issue of the Certificate of Completion.
29. Price Adjustment
- 29.1 The rates and prices in the bill of quantities are fixed for the duration of the Contract and not subject to price adjustment during the performance of the Contract.
30. Completion
- 30.1 The Contractor shall request the Engineer to issue a Certificate of Completion of the Works, and the Engineer will do so upon deciding that the work is substantially completed.

31. Correction of Defects
- 31.1 The Engineer shall give notice to the Contractor of any Defects before the end of the Defects Liability Period, which begins at Completion, and is defined in the SCC. The Defects Liability Period shall be extended for as long as the Defects remain to be corrected.
- 31.2 If the Contractor has not corrected a Defect within the time specified in the Engineer's notice, the Engineer will assess the cost of having the Defect corrected, and the Contractor will pay this amount.
32. Taking Over
- 32.1 The Employer shall take over the Site and the Works within seven (7) days of the Engineer issuing a Certificate of Completion.
33. Final Account
- 33.1 The Contractor shall supply the Engineer a detailed account of the total amount that the Contractor considers payable under the Contract. The Engineer shall certify any final payment that is due to the Contractor within twenty-one (21) days of receiving the Contractor's account if it is correct and complete.
- 33.2 The Employer shall effect payment of the final account within thirty (30) days from the date of certification by the Engineer.
34. Termination
- 34.1 The Employer or the Contractor by giving thirty (30) days written notice of default to the other party, may terminate the Contract in whole or in part if the other party causes a fundamental breach of Contract.
- 34.2 Fundamental breaches of the Contract shall include, but shall not be limited to, the following:
- (a) the Contractor stops work for more than thirty (30) days when no stoppage of work is shown on the current Programme and the stoppage has not been authorised by the Engineer;
  - (b) the Engineer gives notice that failure to correct a particular defect is a fundamental breach of Contract and the Contractor fails to correct it within a reasonable period of time determined by the Engineer;
  - (c) the Contractor has delayed the completion of the Works by the number of days for which the maximum amount of Liquidated Damages can be paid;
  - (d) the Contractor, in the judgment of the Employer, has engaged in corrupt or fraudulent practices, as defined in GCC Clause 3, in competing for or in executing the Contract; and
  - (e) a payment certified by the Engineer is not paid to the Contractor by the Employer within sixty (60) days of the date of the Engineer's certificate.
- 34.3 The Employer and the Contractor may at any time terminate the Contract by giving notice to the other party if either of the parties becomes bankrupt or otherwise insolvent. In such event, termination will be without compensation to any party provided that such termination will not prejudice or affect any right of action or remedy that has accrued or will accrue to the other party.
- 34.4 Notwithstanding the above, the Employer may terminate the Contract for convenience.
- 34.5 If the Contract is terminated, the Contractor is to stop work immediately, make the Site safe and secure and hand over the Site

to the Employer as soon as reasonably possible.

35. Payment upon Termination
- 35.1 If the Contract is terminated because of a fundamental breach of Contract by the Contractor, the Engineer shall issue a certificate for the value of the work done and Plant and Materials ordered less advance payments received up to the date of the issue of the certificate and less the percentage to apply to the value of the work not completed, as indicated in the SCC.. Additional Liquidated Damages shall not apply. If the total amount due to the Employer exceeds any payment due to the Contractor, the difference shall be a debt payable to the Employer.
- 35.2 If the Contract is terminated for the Employer's convenience or because of a fundamental breach of Contract by the Employer, the Contractor shall be entitled to payments for completed works and the materials that have been brought to the site for the purpose of the works, but not used as certified by the Engineer after adjusting any payments received by the Contractor.
36. Release from Performance
- 36.1 If the Contract is frustrated by the outbreak of war or by any other event entirely outside the control of either the Employer or the Contractor, the Engineer shall certify that the Contract has been frustrated. The Contractor shall make the Site safe and stop work as quickly as possible, after receiving this certificate. The Contractor shall be paid for all works carried out before stoppage of work and any work carried out afterwards to which a commitment was made.
37. Force Majeure
- 37.1 For the purposes of this Contract, "Force Majeure" means an exceptional event or circumstance:
- (a) which is beyond a Party's control,
  - (b) which such Party could not reasonably have provided against before entering into the Contract,
  - (c) which, having arisen, such Party could not reasonably have avoided or overcome, and
  - (d) which is not substantially attributable to the other Party.
- 37.2 Force Majeure may include, but is not limited to, exceptional events or circumstances of the kind listed below, so long as conditions (a) to (d) above are satisfied:
- (a) war, hostilities (whether war be declared or not), invasion, act of foreign enemies,
  - (b) rebellion, terrorism, sabotage by persons other than the Contractor's Personnel, revolution, insurrection, military or usurped power, or civil war,
  - (c) riot, commotion, disorder, strike or lockout by persons other than the Contractor's Personnel,
  - (d) munitions of war, explosive materials, ionizing radiation or contamination by radio-activity, except as may be attributable to the Contractor's use of such munitions, explosives, radiation or radio-activity, and
  - (e) natural catastrophes such as earthquake, hurricane, typhoon or volcanic activity.
- 37.3 However, force majeure shall not include the following;
- i. rainfall

ii. snowfall

iii. strikes in other countries

iv. non-availability of labourer and materials such as timbers, boulders, sand, and other materials

v. difficulty and risky terrain and remoteness of site.

38. Settlement of Disputes
- 38.1 The Employer and the Contractor shall use their best efforts to settle amicably all disputes arising out of or in connection with this Contract or its interpretation.
- 38.2 Any dispute between the parties to the Contract that may not be settled amicably will be referred to Arbitration at the initiative of either of the parties.
- 38.3 The Arbitration shall be conducted in accordance with the Arbitration Rules of the Kingdom of Bhutan in force.

## Section 6. Special Conditions of Contract

*Instructions for completing the Special Conditions of Contract are provided, as needed, in the notes in italics mentioned for the relevant GCC Clauses.3*

Clause Ref	Amendments of, and Supplements to, Clauses in the General Conditions of Contract
<b>GCC 1.1(d)</b>	The Contractor is <i>[name, address and name of authorised representative]</i> .
<b>GCC 1.1(i)</b>	The Employer is <i>[Director, Department of Air Transport]</i> .
<b>GCC 1.1(j)</b>	The Engineer is <i>[Jamyang T Dorji (Civil) and Tashi Gyeltshen (Electrical)]</i> .
<b>GCC 1.1(k)</b>	The Intended Completion period for the whole of the Works shall be <i>[4] months from signing of agreement</i> .
<b>GCC 1.1(l)</b>	The Site is located at <i>[Bumthang Domestic Airport]</i> .
<b>GCC 1.1(m)</b>	The Works are <i>[Renovation and maintenance of Airport infrastructures at Bumthang Domestic Airport]</i>
<b>GCC 2.2(i)</b>	The additional documents forming part of this Contract are: None
<b>GCC 4.1</b>	The Language governing the Contract shall be <i>[English]</i>
<b>GCC 5.1</b>	The Engineer shall obtain specific approval of the Employer before taking any of the following actions:
<b>GCC 7.1</b>	The addresses for Communications shall be: <u>For the Employer:</u> <i>[Jamyang T Dorji (Civil Engineer), Tashi Gyeltshen (Electrical Engineer), DoAT]</i> <u>For the Contractor:</u>
<b>GCC 9.1</b>	The Key Personnel of the Contractor are: <i>NA</i>
<b>GCC 15.1</b>	For insurance purposes the type of cover required shall be: The contractor shall be responsible for the insurance of work.
<b>GCC 16.1</b>	Possession of the site shall be within [10] days from the date of signing of the Contract.
<b>GCC 17.1</b>	Commencement of work shall be within [10] days from the date of handing over possession of the Site.
<b>GCC 18.1</b>	Completion of works shall be within [120] days from the date of commencing the works on the site.

<b>GCC 19.1 &amp; 19.2</b>	The Contractor shall submit the first work plan <del>[15] days after signing the Contract,</del> and shall update the work plan every [4] weeks during the period of the Contract.
<b>GCC 22.1</b>	<i>"The rates for non-scheduled items of works shall be determined by the Engineer".</i>
<b>GCC 25.2</b>	An advance payment of [10] % of the Contract Price will be made to the Contractor within (14) days of Contract signing date.
<b>GCC 26.1</b>	The Retention shall be [10] % of the Contract Price.
<b>GCC 27.1</b>	The liquidated damages for the whole of the Works are [0.1 percent of the initial Contract Price] per day. The maximum amount of liquidated damages for the whole of the Works is [10] percent of the initial Contract Price.
<b>GCC 31.1</b>	The Defects Liability Period shall be [1] year.
<b>GCC 35.1</b>	The percentage to apply to the value of the work not completed, representing the Employer's additional cost for completing the Works, is [20] % of initial contract price]

## Section 7 – Contract Forms

This section contains forms which, once completed, will form part of the Contract. The forms for Performance Security and Advance Payment Security, when required, shall only be completed by the successful Bidder after Contract award.

### **Contract Forms**

Form	Title
Form -1	Notification of Award
Form -2	Contract Agreement
Form -3	Bank Guarantee for Performance Security
Form -4	Bank Guarantee for Advance Payment

## **Notification of Award**

Contract No:

Date:

To:

*[name and address of Contractor]*

This is to notify you that your Bid dated *[insert date]* for the execution of the Works for *[name of project / Contract]* for the Contract Price of Nu *[amount in figures and in words]*, as corrected and modified in accordance with the Instructions to bidder is hereby accepted by *[name of the Employer]*.

You are requested to proceed with the execution of the Works on the basis that this Notification of Award shall constitute the formation of a Contract, which shall become binding upon you furnishing a Performance Security within fourteen (14) days, in accordance with ITB Clause 32, and the signing the Contract Agreement within twenty-one (21) days, in accordance with ITB Clause 33.

We attach the Contract Agreement and Special Conditions of Contract for your perusal and signature.

Signed

Duly authorised to sign for and on behalf of  
*[name of Procuring Entity]*

Date:



## Contract Agreement

THIS AGREEMENT, made the [day] of [month] [year] between [name and address of Employer] (hereinafter called "the Employer") of the one part and [name and address of Contractor] (hereinafter called "the Contractor") of the other part.

WHEREAS, the Employer invited Tenders for certain Works, viz, [brief description of the Works] and has accepted a Tender by the Contractor for the execution of those works in the sum of Ngultrum [insert amount in figures and words], hereinafter called "the Contract Price.

NOW THIS AGREEMENT WITNESSETH as follows:

1. In this Agreement, words and expressions shall have the same meanings as are respectively assigned to them in the General Conditions of Contract hereinafter referred to.
2. The documents forming the Contract shall be interpreted in the following order of priority:
  - (a) The signed Contract Agreement;
  - (b) The letter of Acceptance;
  - (c) The completed Bid form as submitted by the Bidder;
  - (d) The Special Conditions of Contract;
  - (e) The General Conditions of Contract;
  - (f) Specifications
  - (g) The Drawings; and
  - (h) Any other document listed in the SCC as forming part of the Contract..

2 In consideration of the payments to be made by the Employer to the Contractor as hereinafter mentioned, the Contractor hereby covenants with the Employer to execute and complete the Works and to remedy any defects therein in conformity in all respects with the provisions of the Contract.

3 The Employer hereby covenants to pay the Contractor in consideration of the execution and completion of the Works and the remedying of defects therein, the Contract Price or such other sum as may become payable under the provisions of the Contract at the times and in the manner prescribed by the Contract.

**IN WITNESS** whereof the Parties thereto have caused this Agreement to be executed in accordance with the laws of Bhutan on the day month and year first before written.

For the Employer

For the Contractor

Signature

Print Name

Title

In the presence of  
(Name)

Address

## Bank Guarantee for Performance Security

*[this is the format for the Performance Security to be issued by any financial institute in Bhutan in accordance with ITB Clause 35]*

Contract No:

Date:

To:

[Name and address of Employer]

### PERFORMANCE GUARANTEE No:

We have been informed that *[name of Contractor]* (hereinafter called "the Contractor") has undertaken, pursuant to Contract No *[reference number of Contract]* dated *[date of Contract]* (hereinafter called "the Contract"), the execution of works *[description of works]* under the Contract.

Furthermore, we understand that, according to your conditions, Contracts must be supported by a performance guarantee.

At the request of the Contractor, we *[name of bank]* hereby irrevocably undertake to pay you, without cavil or argument, any sum or sums not exceeding in total an amount of Nu *[insert amount in figures and in words]* upon receipt by us of your first written demand accompanied by a written statement that the Contractor is in breach of its obligation(s) under the Contract conditions, without you needing to prove or show grounds or reasons for your demand of the sum specified therein.

This guarantee is valid until *[date of validity of guarantee]*, consequently, we must receive at the above-mentioned office any demand for payment under this guarantee on or before that date.

Signature

Signature

## Bank Guarantee for mobilisation advance

*[this is the format for the Advance Payment Guarantee to be issued by a financial institutions in Bhutan in their letter pad in accordance with SCC Clause 25.2]*

Contract No:

Date:

To:

[Name and address of Employer]

### ADVANCE PAYMENT GUARANTEE No:

We have been informed that *[name of Contractor]* (hereinafter called "the Contractor") has undertaken, pursuant to Contract No *[reference number of Contract]* dated *[date of Contract]* (hereinafter called "the Contract"), the execution of works *[description of works]* under the Contract.

Furthermore, we understand that, according to your conditions, Advance Payments must be supported by a bank guarantee.

At the request of the Contractor, we *[name of bank]* hereby irrevocably undertake to pay you, without cavil or argument, any sum or sums not exceeding in total an amount of Nu. *[insert amount in figures and in words]* upon receipt by us of your first written demand accompanied by a written statement that the Contractor is in breach of its obligation(s) under the Contract conditions, without you needing to prove or show grounds or reasons for your demand of the sum specified therein.

We further agree that no change, addition or other modification of the terms of the Contract to be performed, or of any of the Contract documents which may be made between the Employer and the Contractor, shall in any way release us from any liability under this guarantee, and we hereby waive notice of any such change, addition or modification.

This guarantee is valid until *[date of validity of guarantee]*, consequently, we must receive at the above-mentioned office any demand for payment under this guarantee on or before that date.

Signature

Signature

**Section 8**  
**Bill of Quantities (BoQ)**

<b>BoQ</b>					
<b>Construction of water reservoir and stand</b>					
<b>BSR Code</b>	<b>Description of activities</b>	<b>Qty</b>	<b>Unit</b>	<b>Rate</b>	<b>Amount</b>
EW0105	Excavation in foundation trenches or drains not exceeding 1.5m in width or area 10 sq.m on plan, including dressing & ramming, disposal of surplus soil within 50m lead & 1.5m lift				
		18.43	cum		
SM0072	Providing and laying Hand packed stone filling or soling with stones				
		1.35	cum		
CW0005	Providing and laying in position plain cement concrete excluding the cost of centering and shuttering - All work upto plinth level. 1:3:6 (1 cement : 3 sand : 6 graded crushed rock 20 mm nominal size)				
		1.35	cum		
RC0002	Providing & laying in position reinforced cement concrete excluding the cost of centering, shuttering and reinforcement - all work upto plinth level: 1:1.5:3 (1 cement : 1.5 sand : 3 graded crushed rock 20 mm nominal size)				
		3.89	cum		
EW0195	Filling of trenches, sides of foundations etc. in layers <200mm using selected excavated earth, ramming etc. within lead 50 m & lift 1.5m				
		11.84	cum		
RC0090	Providing & fixing centering and shuttering (formwork), including strutting, propping etc. and removal of formwork Foundation and plinth				
		23.28	sqm		

RC0083	Providing & fixing Thermo-Mechanically Treated reinforcement bar (Yield Strength 500 MPa) for R.C.Cwork including cutting, bending, binding and placing in position complete				
		446.91	kg		
SW0080	Providing & fixing M.S. round hold-down bolts with nuts and washer plates				
		32.00	kg		
SW0090	Providing, making and fixing M.S. straps, flats, sole plates etc.				
		80.00	kg		
SW0010	Steel work riveted or bolted, in built up sections, trusses, frame-works, including cutting, hoisting, fixing and appl. priming coat of red lead paint: In R.S. joists				
	Column (ISMB 150x80)	196.68			
	Primary beam ISLB 100x50	36.80			
		233.48	kg		
SW0021	Steel work welded, in built up sections, trusses, frame-works including cutting, hoisting, fixing and appl. priming coat of red lead paint: In Tees, angles, flats and channels				
	Secondary beam (ISMC 100x50)	115.00			
	Flooring plate (8mm)	226.08			
	Struts MSA 65x65x6	271.59			
	25mm dia bar	15.56			
	MS Angle 30x30x3 ladder	23.52			
		651.75	kg		
PI0034	Providing & fixing plastic tank including all accessories (tank nipple for incoming and outgoing along with air vent pipe, washout pipe of 3" with gate valve, overflow control float valve/overflow pipe and all accessories complete: 3000 litre capacity (Bhutan made: 3 layered)				
		1.00	each		

	Providing & laying G.I. pipes including G.I. fittings (excluding trenching, refilling & thrust block)				
PO0004	32mm	6.50	m		
PO0008	80mm	4.00	m		
PO0643	Providing & laying H.D.P.E pipes, 12.5 PN Bhutan made, including H.D.P.E fittings (excluding trenching, refilling & thrust block): 40mm				
		30.00	m		
PO0109	Providing & fixing brass full way valve with wheel: 80mm				
		1.00	each		
EW0135	Hand excavation and refilling in layers < 200mm, of trenches for pipes & sockets, cables, including dressing of sides/ ramming of bottom, depth upto 1.5m, disposal of surplus material within lead of 50m: All kinds of soil				
		30.00	m		
				<b>Total (Tank)</b>	

Electrical BoQ					
BSR Code	Description	Qty	Unit	Rate	Amount
	Wiring of light, fans, and 2 pin light socket outlet with 1.5 sq.mm 1.1kV grade, PVC insulated copper conductor cable in PVC casing and capping including providing, connections, painting, testing & commissioning of all the accessories item complete as required				
WC0300	Short Point	4	point		
WC0301	Medium Point	5	point		
WC0302	Long Point	8	point		
	Wiring for 6/16 ampere multipin plug point with 4 sq.mm 1.1kV grade, PVC insulated copper conductor cable in PVC casing capping including providing and fixing of 6/16 ampere socket outlets and switches including earthing the third pin and providing, connections, painting, testing and commissioning of all the accessories items complete as required				
WC0342	Long Point	10	point		
	Wiring for points in excess length above long points with 1.1kV grade, PVC insulated copper conductor cable in recessed HDPE pipe including providing, connections, painting, testing and commissioning of all the accessories items complete required				
WC0382	2x4 sq.mm	120	m		
	Wiring for lighting circuit with 1.1kV grade, PVC insulated copper conductor cable in PVC casing capping pipe including providing, connections, painting, testing & commissioning of all the accessories item complete as required				
WC0391	2x2.5 sq.mm	100	m		
	<b>Lighting fixtures and accessories</b>				
	Supply of surface mounted LED downlighter with durable housing with Al heat sink with diffuser to give glare free light with removable driver				
A/R	BOLT ROUND, 12W, 4000K Odering code: LHEAARP6UL1W012	4	each		
A/R	BOLT SQUARE, 12W, 4000K. Odering code: LHEAASP6UL1W012	4	each		

A/R	Supply of 18W surface mounted LED batten with polycarbonate housing & integrated electronic driver. Oding code: LHEXBQP5IN1W018	3	each		
A/R	Supply and fixing of adjustable angle batten holder (64mm diameter base) suitable for fitting general energy saving CFL lamps or LED lamps	2	each		
A/R	Supply of 18W, 230V twisted type CFL energy saving lamp suitable to fit in pendent holder	4	each		
	<b>CONTROL GEAR AND PROTECTIONS</b>				
	Supply of TPN distribution board (DIN type, horizontal)with metal door, 415 volt A.C complete with all accessories but without MCB/isolator/RCCB out going or incoming etc. as required				
GB0540	6 ways	1	each		
	Supply of miniature circuit breaker (MCB) single pole, 230 volt A.C complete with all accessories suitable to fix on a din-bar etc. as required				
GB0270	6A	4	each		
GB0272	16A	10	each		
	Supply of miniature circuit breaker (MCB) triple pole, 415 volt A.C complete with all accessories suitable to fix on a dinbar etc. as required				
GB0355	63A	1	each		
	<b>Power Cable Supply</b>				
	<b>Erection and Installation of lighting fittings and control gears</b>				
	Installation, testing and commissioning of prewired LED/CFL fittings of all surface/pendent type complete with all accessories and tubes/lamps directly on ceiling/wall as required including connection with PVC insulated copper conductor				
EI0041	1.5 sq.mm single core cable 1.1 KV grade	13	each		
	Installation, testing and commissioning of TPN 63A, 415V miniature circuit breaker (DIN type) complete with all accessories to accommodate wooden panel board including drilling holes, connections etc as required	1	each		



	Installation, testing and commissioning of SP miniature circuit breaker complete with all accessories to accommodate in TPN sub-distribution board including drilling holes, connections etc as required				
EI0380	6A	4	each		
EI0380	16A	10	each		
	Installation, testing and commissioning of TPN DB (DIN type, horizontal/vertical) with metal door complete with all accessories to accommodate incoming 63A TPN MCB and outgoing SP MCB 6/16A including drilling holes, connections etc. as required				
EI0535	6 ways	1	each		
	<b>EARTHING</b>				
	Providing and fixing of earthing including all accessories, machinery enclosure, C.I cover plate having locking arrangement, watering pipe with excavation and refilling work including charcoal or coke and salt complete as required as per standard earthing drawing				
ET0001	With G.I earth plate 600x600x6mm	1	each		
	Providing and drawing wire for loop earthing in recessed HDPE conduit along with power point wires as required				
ET0121	2.032mm (14SWG) copper wire	150	m		
	Providing and laying earth connection from earth electrodes in 15mm dia G.I pipe from earth electrodes as required as per guidance of standard earthing drawing				
ET0015	With 4.06mm dia (8SWG) G.I wire	10	m		
			<b>Total (Electrical)</b>		

<b>BoQ</b>					
<b>Maintenance of infrastructures and runway maintenance</b>					
<b>Bumthang Domestic Airport</b>					
<b>BSR Code</b>	<b>Particulars</b>	<b>Oty</b>	<b>Unit</b>	<b>Rate</b>	<b>Amount</b>
	<b>Airport Guest House</b>				
DD0065	Dismantling plyboard, partition, including stacking useful materials & disposal rubbish within the airport as instructed by supervising official.				
		34.22	sqm		
DD0040	Dismantling wooden flooring including stacking useful materials & disposal of rubbish at area specified by the department				
	Sitting room	34.22			
	Kitchen	8.1			
	Room	15.75			
	Room 1	15.75			
		73.82	sqm		
FL0203	Providing & fixing Mixed Conifer Flooring including fixing with iron screws etc. complete, excluding the cost of frame: 40mm thick, half-lapped				
	Sitting room	34.22			
	Kitchen	8.1			
	Room	15.75			
	Room 1	15.75			
		73.82	sqm		
PT0012	Providing & applying one coat of primers: Wood work - pink primer including the cost of repair of ceiling and the ceiling frame wherever necessary				
	Sitting room ceiling	34.22			
	Kitchen ceiling	8.37			
	Porch ceiling	9			
	Room ceiling	15.75			
	Room 1 ceiling	15.75			
	Toilet	11.44			
		94.53	sqm		
PT0047	Providing and applying finishing coats: Synthetic enamel, for steel & wood work, two coats on new work				
	Sitting room ceiling	34.22			
	Kitchen ceiling	8.37			
	Porch ceiling	9			

	Room ceiling	15.75			
	Room 1 ceiling	15.75			
	Toilet	11.44			
		94.53	sqm		
PT0064	Providing and applying wood stains, varnishes & polishes: French polish - two coats, on new work				
	Sitting room wall panels	63.18			
	Porch	8.1			
		71.28	sqm		
WW0506	Providing & fixing 100x12mm, with 25mm dia. wooden curtain rod and brackets including M.S flats 25x3x100mm and plugs etc. complete: Mixed Conifer				
	W3	11			
	W4	15			
		26	m		
WW0003	Providing & fixing in position dressed wood work in frames of doors, windows, clerestory windows and other frames, wrought and framed: Mixed Conifer				
	Vertical	0.093			
		0.04			
	Horizontal	0.146			
		0.075			
		0.354	cum		
WW0112	Providing & fixing Pre-laminated Particle Board Lining with necessary nails etc. complete (excluding cost of frame): 12 mm				
		15.5			
		15.5	sqm		
	Providing & fixing Electric water heater including necessary fittings				
PI0161	Kitchen (15 litres)	1	each		
PI0222	Providing & fixing c.p. brass mixers, 15mm: For wall, non-telephonic type				
	Kitchen sink	1.00	each		
PT0052	Providing and applying finishing coats: Vinyl plastic emulsion paint, for cement, masonry, plaster, two coats				
	Kitchen	32.94			
	Porch	8.1			
	Room 1 wall	43.2			
		84.24	sqm		

WW0211	Providing & fixing 35mm thick Panelled or glazed doors and windows Shutters etc. complete including hinges, towerbolt and sliding door bolt as per the sample approved by the supervising engineer including repair of frame wherever necessary: MC				
	Kitchen back door	1.46			
	Kitchen door	1.81			
	Window shutter	1.38			
	Room 1 door	1.40			
		6.05	sqm		
NA	Providing and fixing aluminum partition using the sections provided in the drawing including plain particle board of 10mm/plain glass (shaded with approved sticker to glaze the glass). The partition should be inclusive of one set swing door with all accessories (lock & key, handle, door bolt etc. complete)				
	Porch	12.88	sqm		
NA	Removal of window and mofication of the window with door of 750 mm x 1700 mm door along with all accessories including the repair/modification of wall as per the instruction of supervising official				
		2.00	no		
BW0002	Providing & laying Second-Class Brick work superstructure above plinth level, up to floor two level: In cement mortar 1:4				
	Room 1 wall	2.07	cum		
PL0041	Providing & laying 20mm cement plaster: C.M 1:4				
		13.80	sqm		
PT0010	Providing & applying one coat of primers: Cement primer				
	Toilet	12.00			
		13.80			
		25.80	sqm		
PT0020	Providing & applying white or colour washing: White washing with lime-new work-three coats				
	Toilet	12.00			
		13.80			
		25.80	sqm		

	Providing and fixing DP Debo toilet partition including doors, Locks and accessories toilet paper holder & robe hook as per Manufacturer's specification (for two toilets)				
		4			
		6			
		10	sqm		
BW0021	Providing & laying Second-Class Half-brick Masonry (125 mm) in superstructure below floor 2 level: In cement mortar 1:4				
		4			
		4.4			
	Less Doors	-2.72			
		5.68	sqm		
PL0031	Providing & laying 15mm cement plaster on rough side of single or half-brick wall: In cement mortar 1:4				
		8			
		8.8			
	Less Doors	-5.44			
		11.36	sqm		
DD0017	Demolishing brick work including stacking useful materials & disposal of rubbish within 50m lead: In cement mortar				
		1.69	cum		
WW0055	Providing & fixing Mixed Conifer (undressed) in wallframes etc.				
		0.13	cum		
WW0130	Providing & fixing Plywood lining with necessary nails etc. including beading complete (excluding cost of frame): 4 mm, commercial				
	Toilet	11.96	sqm		
	Providing & fixing P.V.C soil waste and vent pipes, single or double socketed, including pipe clip complete (excluding the cost of PVC fittings)				
PO0372	110mm dia	65.00	m		
PO0370	75mm dia	7.50	m		
	Providing & fixing P.V.C plain bend				
PO0407	110mm dia	4.00	each		
PO0405	75mm dia	7.00	each		
	Providing & fixing P.V.C door bend				
PO0417	110mm dia	2.00	each		

	Providing & fixing P.V.C Single Tee plain				
PO0437	110mm dia	1.00	each		
PO0435	75mm dia	3.00	each		
PO0565	Providing & fixing P.V.C Nahani Trap: 110mm inlet & 75mm outlet				
		3.00	each		
RA002	Providing and fixing white vitreous china wash basin (1005A over counter wash basin 550x460mm(Ivory color) including C.I brackets C.P chain				
		3	Each		
RA005	Providing and fixing C.P towelrail 750x20mm with C.P brass brackets fixed wooden cleats: Standard quality				
		3	Each		
RA006	Providing and fixing basin mixer 15mm 21011 stealth				
		3	Each		
RA007	Providing and fixing Angle stop cock 15mm 21053B stealth				
		10	Each		
PI0165	Providing and fixing Electric water heater including necessary fittings 70 liters				
		1	Each		
RA010	Providing and fixing E.T type vitreous china W.C (Italian collection) Demos Cat No. 9204				
		2	Each		
RA0015	Providing and fixing Connection pipe (heavy duty) 24"				
		8	Each		
RA017	Providing and fixing 32mm wash basin coupling				
		3	Each		
RA009	Providing and fixing C.P grate 110mm. The existing grate should be modified as instructed by the client				
		2	Each		
FL0050	Providing and Laying cement concrete flooring 1:2:4 finished with floating coat of neat cement 12mm aggregate 25 mm thick				
		11.44	sqm		
RA020	Providing and fixing mirror large including frame.				

		2.70	sq.m		
	Providing and fixing of door including priming, painting and accessories complete as per drawing				
		2	each		
PI0001	Providing & fixing G.I. pipes including G.I. fittings & clamps & repair walls: 15mm				
		30	m		
RC0015	Providing & laying in position reinforced cement concrete work in kitchen slab: 1:2:4 (1 cement : 2 sand : 4 graded crushed rock 20 mm nominal size)				
		1.6	cum		
BW0002	Providing & laying Second-Class Brick work in CM 1:4				
		6.975	cum		
PI0123	Providing & fixing Kitchen Sinks including all connections and fittings: Stainless steel, 940 x 460 x 160 mm, single bowl & drainboard				
		5	each		
PO0370	Providing & fixing P.V.C soil waste and vent pipes, single or double socketed, including pipe clip complete (excluding the cost of PVC fittings)				
	75mm dia	25	m		
PI0001	Providing & fixing G.I. pipes including G.I. fittings & clamps & repair walls: 15mm				
		30	m		
DR0106	Constructing Brick masonry manhole in cement mortar 1:5, R.C.C top slab with 1:2:4 20mm aggregates, foundation concrete 1:4:8 40mm aggregates, 12mm plaster in CM 1:3 finished with floating coat of neat cement and making channels in cement concrete 1:2:4 20mm aggregates, neatly finished complete: Inside dimension 900 x 800mm & 600mm deep including C.I. cover & frame (weight >38 kg)				
		5	each		
RC0083	Providing & fixing Thermo-Mechanically Treated reinforcement bar (Yield Strength 500 MPa) for R.C.C work including cutting, bending, binding and placing in position complete				
		60	kg		

PO0614	Constructing Septic Tanks, in R.R Masonry in cement mortar 1:6, including fittings, C.I cover with frame, 40mm thick concrete flooring (40mm aggregates) cement plaster concrete base in C.C 1:4:8 etc. complete as per standard design: 100 users				
		1	each		
		<b>Total for civil</b>			
		<b>Total for electrical</b>			
		<b>Total (Tank)</b>			
		<b>Grand Total</b>			

**Total for all work Nu .....**



## Section 9. Drawings

### 1. Reservoir (tank) stand

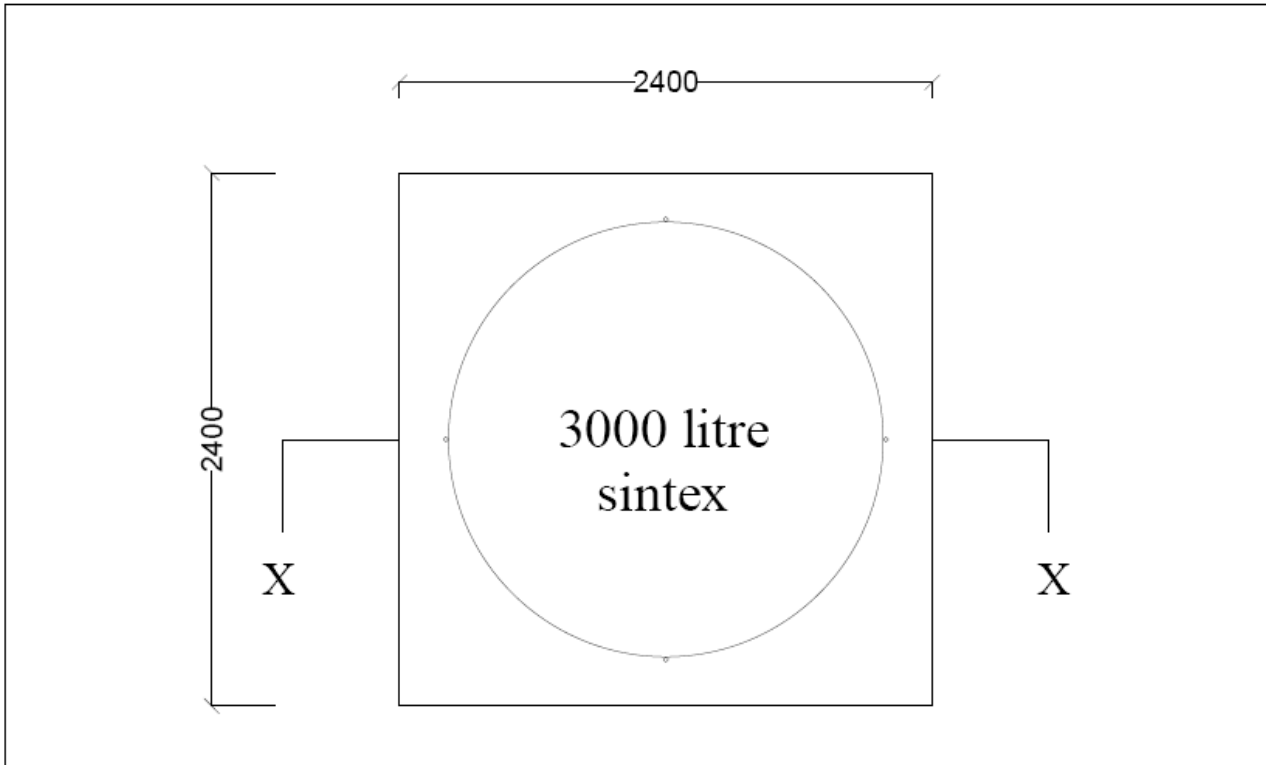

REV.	DATE	NOTES	SCALE: NTS	PROJECT: Construction of water reservoir tank and stand	ROYAL GOVERNMENT OF BHUTAN	
0.00	08.08.17		DATE: 8 August 2017	Drawing title: Plan	 Department of Air Transport Ministry of Information and Communications	
			DRAWN BY:	ENGINEER:		CHECKED BY:
						APPROVED BY:

D:\2017-18\3. RGoB\1. Drawing\Tank stands.dwg, 9/28/2017 10:59:52 AM, DWG To PDF.pc3

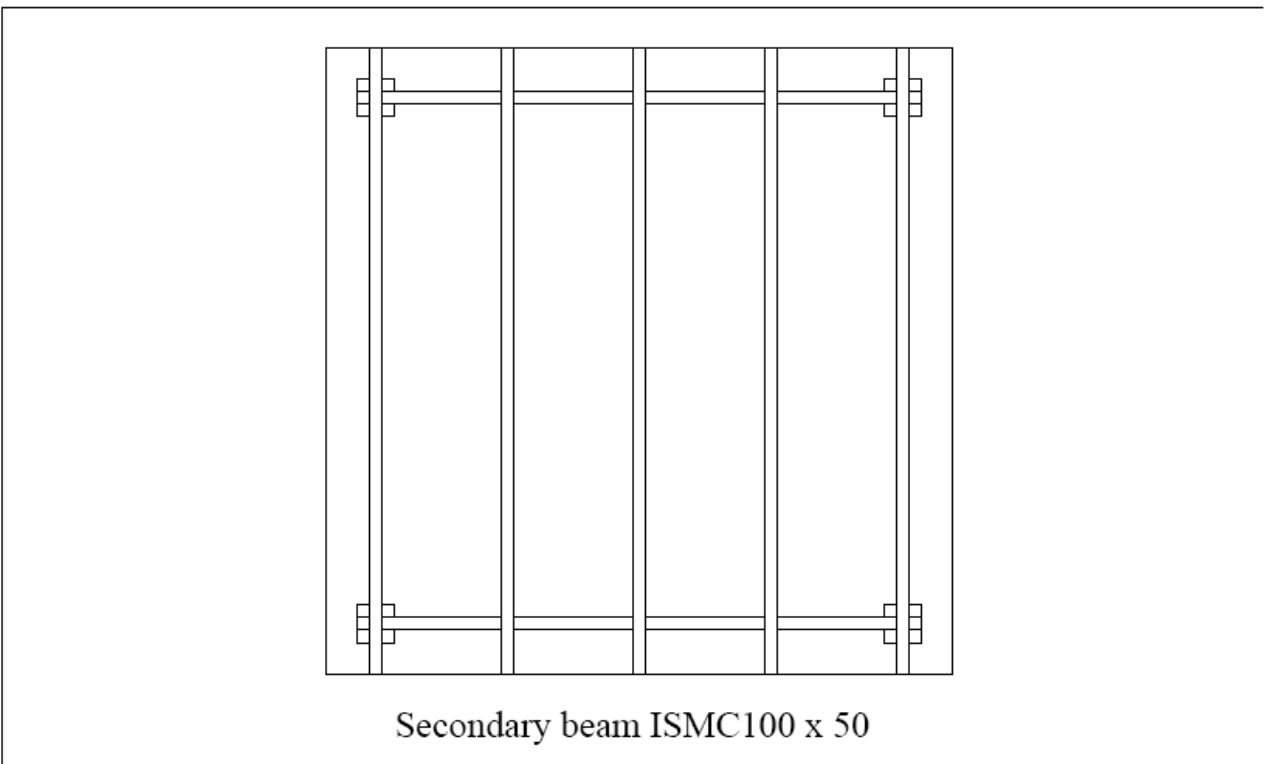

**Secondary beam ISMC100 x 50**

REV.	DATE	NOTES	SCALE: NTS	PROJECT: Construction of water reservoir tank and stand	ROYAL GOVERNMENT OF BHUTAN	
0.00	08.08.17		DATE: 8 August 2017	Drawing title: Secondary beam layout plan	 Department of Air Transport Ministry of Information and Communications	
			DRAWN BY:	ENGINEER:		CHECKED BY:
						APPROVED BY:

D:\2017-18\3. RGoB\1. Drawing\Tank stands.dwg, 9/28/2017 10:59:54 AM, DWG To PDF.pc3

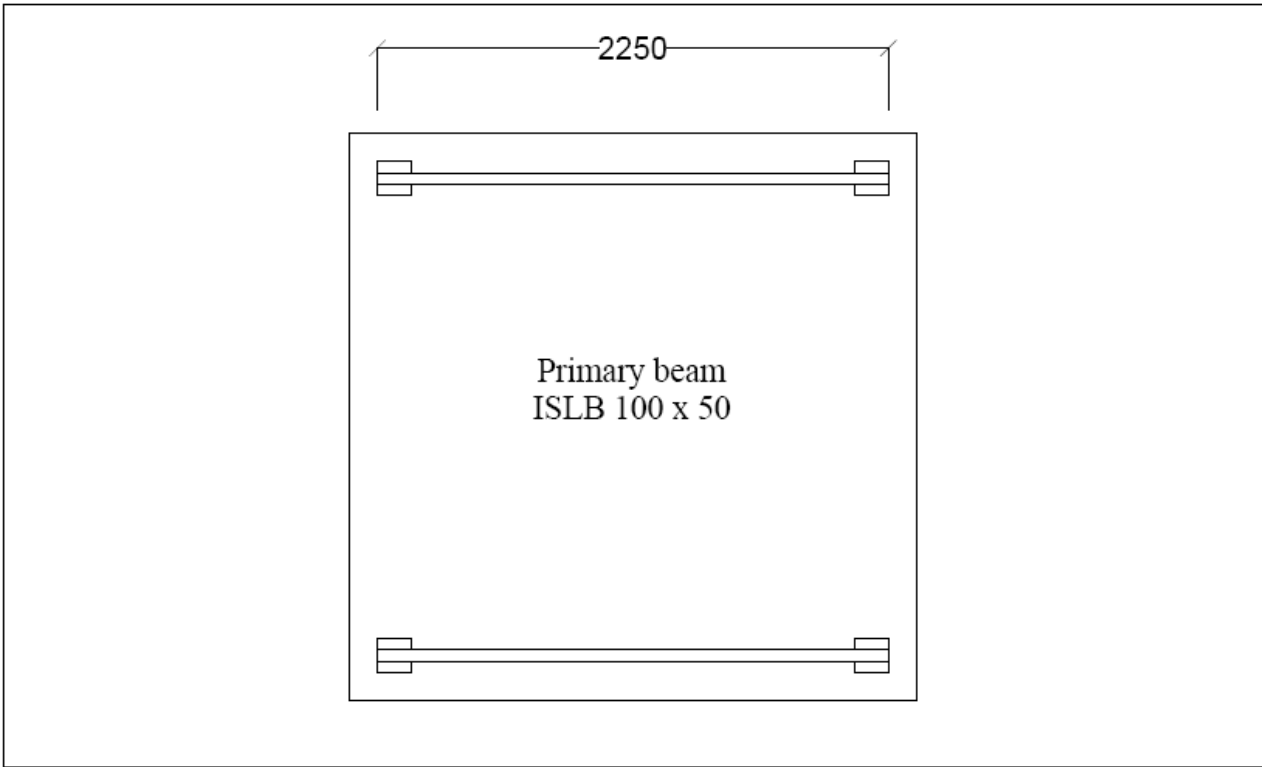

REV. DATE	NOTES	SCALE: NTS	PROJECT: Construction of water reservoir tank and stand	ROYAL GOVERNMENT OF BHUTAN	
0.00 08.08.17		DATE: 8 August 2017	Drawing title: Primary beam layout plan		
		DRAWN BY:	ENGINEER:		CHECKED BY:
					APPROVED BY:

D:\2017-18\3. RGoB\1. Drawing\Tank stands.dwg, 9/28/2017 10:59:54 AM, DWG To PDF.pc3

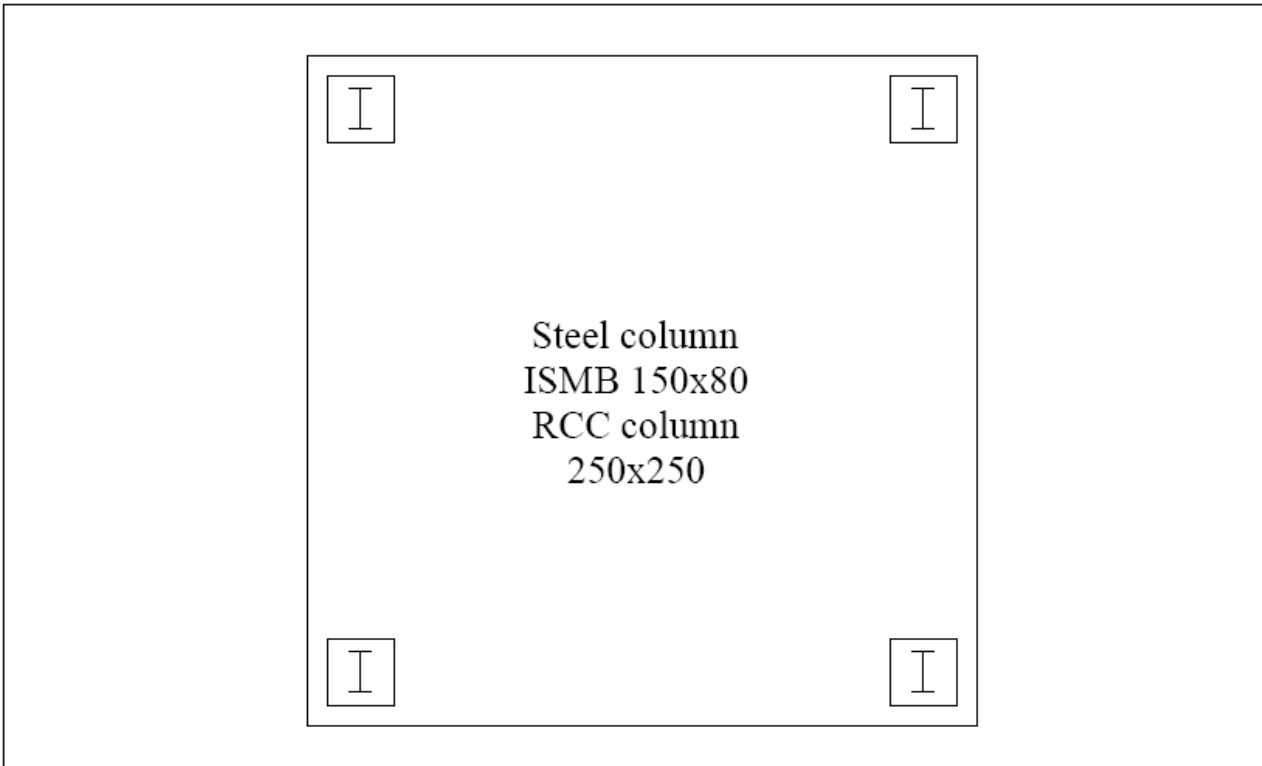

REV. DATE	NOTES	SCALE: NTS	PROJECT: Construction of water reservoir tank and stand	ROYAL GOVERNMENT OF BHUTAN	
0.00 08.08.17		DATE: 8 August 2017	Drawing title: Column layout plan		
		DRAWN BY:	ENGINEER:		CHECKED BY:
					APPROVED BY:

D:\2017-18\3. RGoB\1. Drawing\Tank stands.dwg, 9/28/2017 10:59:55 AM, DWG To PDF.pc3

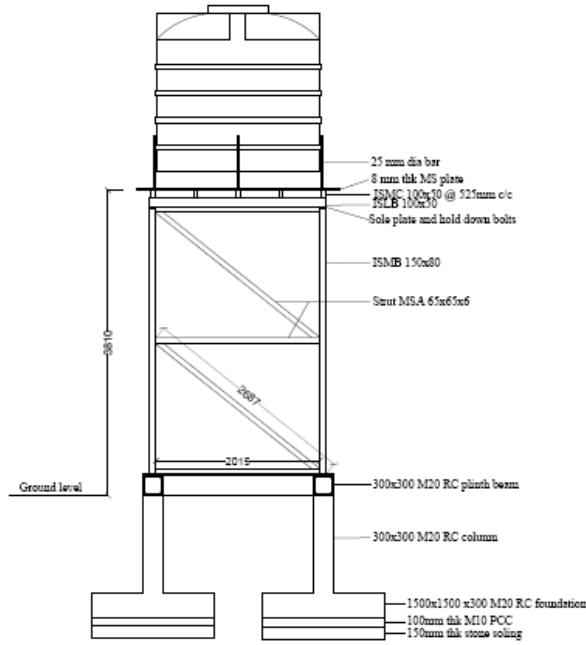

REV. DATE	NOTES	SCALE: NTS	PROJECT: Construction of water reservoir tank and stand	ROYAL GOVERNMENT OF BHUTAN	
0.00 08.08.17		DATE: 8 August 2017	Drawing title: Section XX		
		DRAWN BY:	ENGINEER:		CHECKED BY:
					APPROVED BY:

D:\2017-18\3. RGoB\1. Drawing\Tank stands.dwg, 9/28/2017 10:59:58 AM, DWG To PDF.pc3

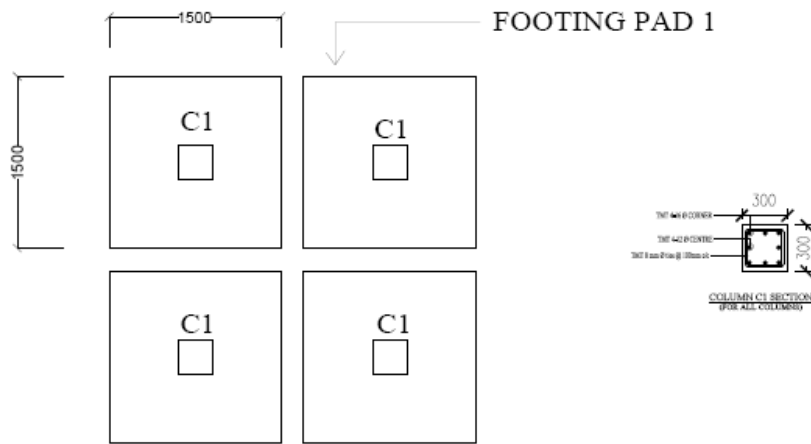

SCHEDULE OF FOOTING AND COLUMN					
FOOTING	SIZE		DEPTH	COLUMN DETAIL	
	Length	Breadth		Area	Shape
PA0-1	1500	1500	300	100x100 c/c @ 100 mm	100x100 c/c @ 100 mm

- General instructions:**
- Grade of concrete for RC footing shall be M20.
  - Grade of steel/bars for RC beam shall be Fe 500 (B55 approved brands).
  - Approximate total RC weight shall be of normal mix. (Given)
  - Water for the footing shall be used for concrete mix design.
  - Minimum clear cover to the footing reinforcement...50 mm.

### FOOTING AND COLUMN DETAILS

REV. DATE	NOTES	SCALE: NTS	PROJECT: Construction of water reservoir tank and stand	ROYAL GOVERNMENT OF BHUTAN	
0.00 08.08.17		DATE: 8 August 2017	Drawing title: Foundation and column detail		
		DRAWN BY:	ENGINEER:		CHECKED BY:
					APPROVED BY:

D:\2017-18\3. RGoB\1. Drawing\Tank stands.dwg, 9/28/2017 10:59:57 AM, DWG To PDF.pc3

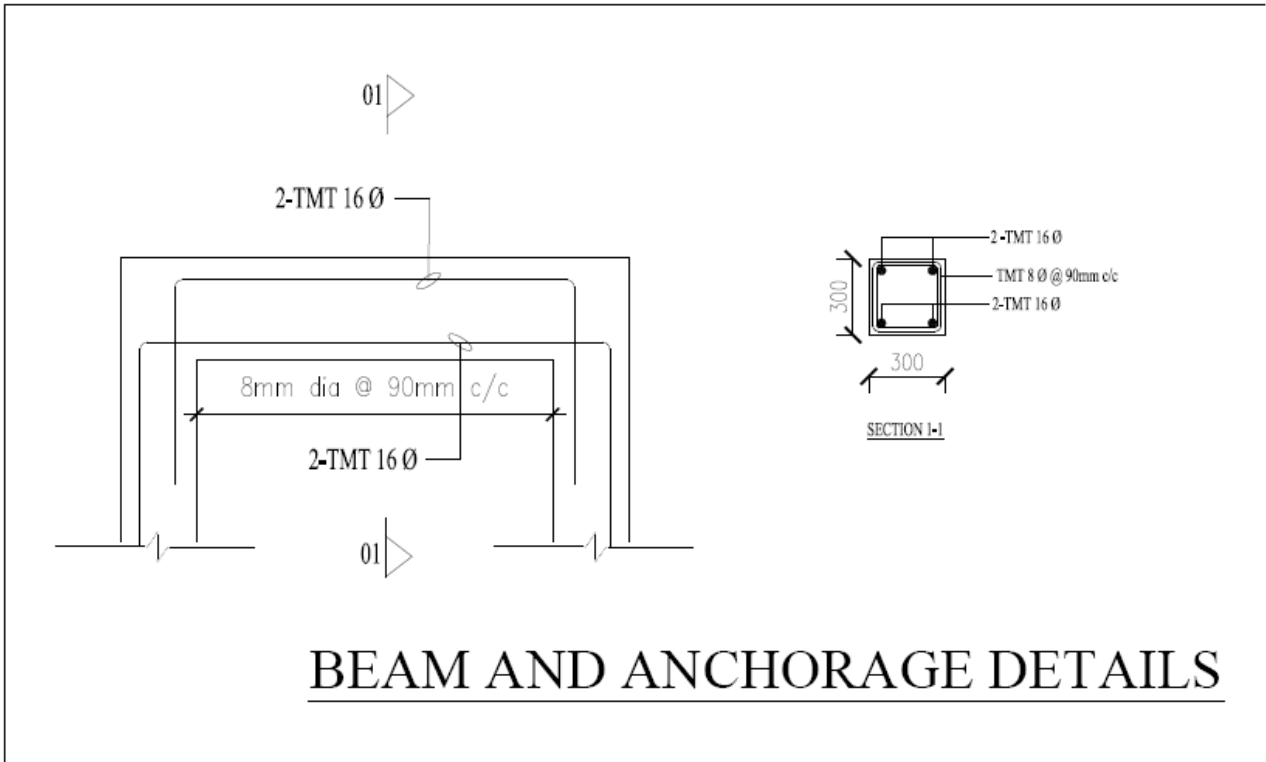

## BEAM AND ANCHORAGE DETAILS

REV.	DATE	NOTES	SCALE: NIS	PROJECT: Construction of water reservoir tank and stand	ROYAL GOVERNMENT OF BHUTAN	
0.00	08.08.17		DATE: 8 August 2017	Drawing title: Beam details	 Department of Air Transport Ministry of Information and Communications	
			DRAWN BY:	ENGINEER:		CHECKED BY:
						APPROVED BY:

D:\2017-18\3. RGoB\1. Drawing\Tank stands.dwg, 9/28/2017 10:59:58 AM, DWG To PDF.pc3

### 2. Infrastructure renovation

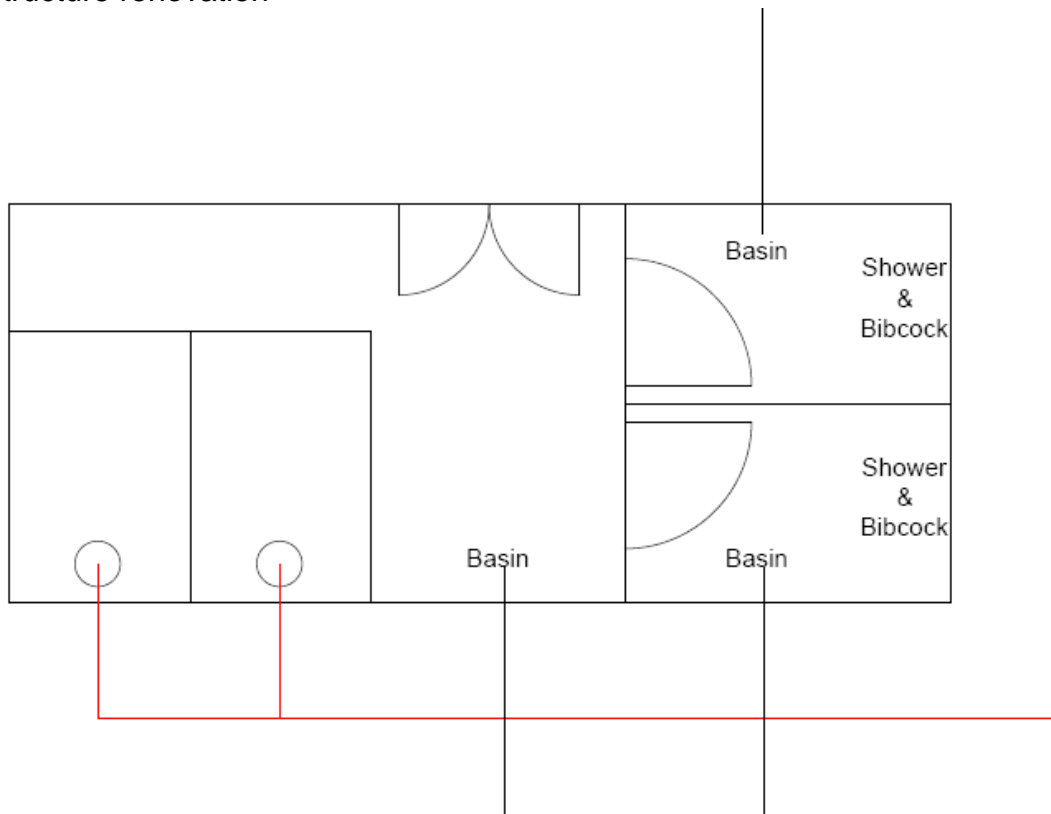

Toilet modification plan

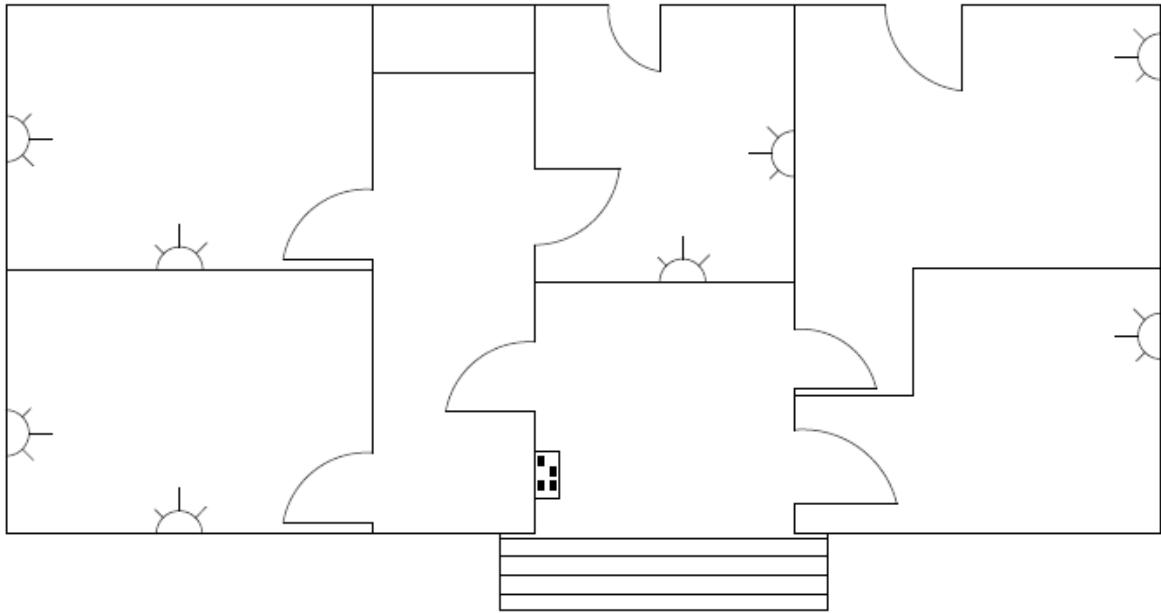

Electrical Plan

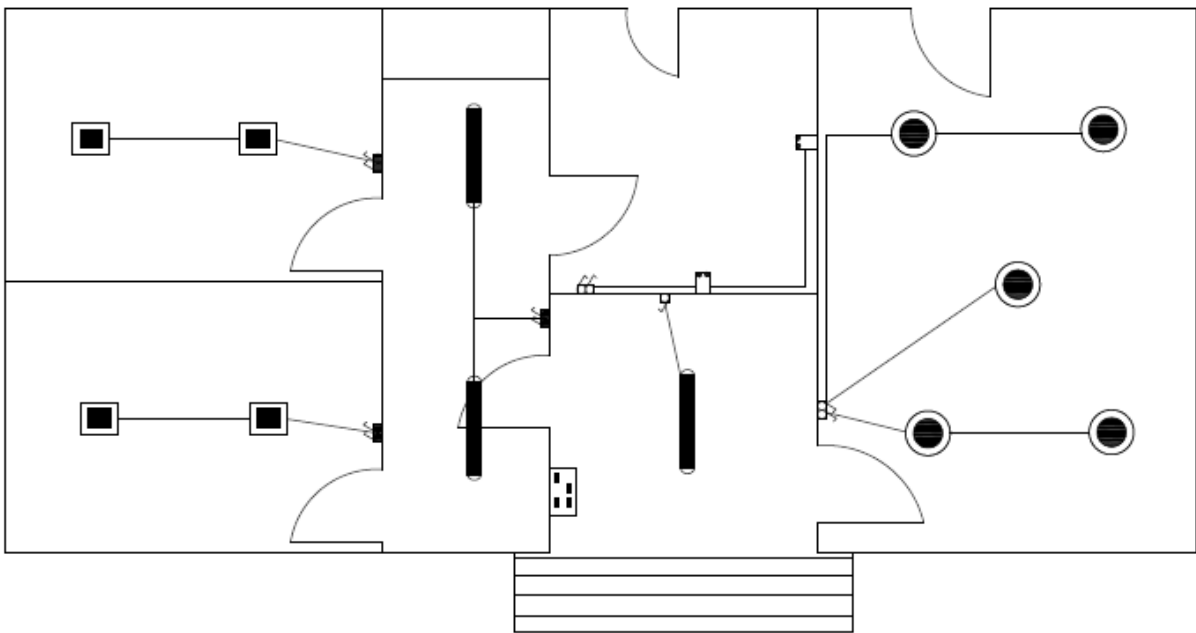

Electrical Plan