

W-5

**PROCUREMENT OF CIVIL WORKS
UNDER
SHOPPING PROCEDURES**

(For Works valued less than equivalent of \$ 100,000 each)

**INVITATION FOR QUOTATIONS FOR CONSTRUCTION OF
CIVIL WORKS UNDER SHOPPING PROCEDURES**

To

Dear Sirs,

Sub: INVITATION FOR QUOTATIONS FOR CONSTRUCTION OF LANDING PAD
AT SAMTSE

1. You are invited to submit your most competitive quotation for the following works:-

Brief Description of the Works	Approximate value of Works (Nu.)	Period of Completion
Construction of landing pad at Samtse	Nu. 0.95 M	60 days

2. Royal Government of Bhutan has received a credit from the International Development Association (IDA) in various currencies equivalent to US\$ 40,000 towards the cost of the development of ten helipads through the Hydromet Services & Disaster Resilience Regional Project and intends to apply part of the proceeds of this credit to eligible payments under the contract for which this invitation for quotations is issued.

3. To assist you in the preparation of your quotation, we are enclosing the following:

- i. Layout Drawings of the works;
- ii. Structural Details;
- iii. Detailed Bill of Quantities;
- iv. Technical Specifications;
- v. Instructions to Bidders (in two sections).
- vi. Draft Contract Agreement format which will be used for finalizing the agreement for this Contract.

4. You are requested to provide your offer latest by 14:00 Hrs. on 24th February 2020.

5. Quotations will be opened in the presence of Bidders or their representatives who choose to attend at 14:30 Hrs on 24th February 2020 in the office of Department of Air Transport, Paro International Airport, MoIC.

6. We look forward to receiving your quotations and thank you for your interest in this project.

(Employer)

Name: Karma Wangchuk
Address: Director
Department of Air Transport
Paro International Airport
Tel. No: +975-8-271403
Fax No. +975-8-271750

Instructions to Bidders

SECTION - A

1. Scope of Works

The **Director, Department of Air Transport** (Employer) invites quotations for the construction of works as detailed in the table given below

Brief Description of the Works	Approximate value of Works (Rs.)	Period of Completion
Construction of landing pad (rigid pavement), installation of windsocks and marking of landing pad at Samtse	Nu. 0.95M	60 days

The successful bidder will be expected to complete the works by the intended completion date specified above.

2. **Qualification of the bidder:** The bidder shall provide qualification information which shall include:-

- (a) Total monetary value of construction works performed for each year of the last 3 years: (will be verified with etool of Construction Development Board of Bhutan)
- (b) Details of any litigation, current or during the last 3 years in which the bidder is involved, the parties concerned, and disputed amount in each case.

3. To qualify for award of the contract the bidder:-

- (a) Should have satisfactorily completed as a prime contractor at least one similar work of value not less than Nu. 500,000 in the last three years;
- (b) Should possess required valid license/s and tax clearance certificate for executing the extension of landing pad and associated works;

4. **Bid Price**

- a) The contract shall be for the whole works as described in the Bill of quantities, drawings and technical specifications. Corrections, if any, shall be made by crossing out, initialing, dating and re writing.
- b) All duties, taxes and other levies payable by the contractor under the contract shall be included in the total price.
- c) The rates quoted by the bidder shall be fixed for the duration of the contract and shall not be subject to adjustment on any account.

d) The rates should be quoted in Bhutanese Ngultrum only.

5. Submission of Quotations

5.1 The bidder is advised to visit the site of works at his/her own expense and obtain all information that may be necessary for preparing the quotation. Further, the type of material for the aviation windsock should be inspected prior to quoting the rate

5.2 Each bidder shall submit only one quotation (along with an identical copy). Bidders shall not contact other Bidders on matters relating to this quotation.

5.3 The quotation submitted by the bidder shall comprise the following:-

- (a) Quotation in the format given in Section B.
- (b) Signed Bill of Quantities ; and
- (c) Qualification information form given in Section B duly completed.

5.4 The bidder shall seal the quotation in an envelope addressed to the Director, Department of Air Transport. The envelope will also bear the following identification:-

- Quotation for **Construction of landing pad at Samtse**
- Do not open before 1400 hrs 24th February 2020

5.5 Quotations must be received in the office of the Airport Development Division, Department of Air Transport, 2nd Floor, Arrival Terminal, Paro International Airport (Employer) not later than the time and date given in the letter of invitation. If the specified date is declared a holiday, quotations shall be received upto the appointed time on the next working day. The quotation should be submitted with bid security amounting to Nu. 19,000.00 (Nu. Nineteen thousand only) in favour of Director, DoAT without which the bid will not be evaluated. The bid security should be valid upto 30 days from bid validity.

5.6 Any quotation received by the Director, Department of Air Transport after the deadline for submission of quotations will be rejected and returned unopened to the bidder.

6. Validity of Quotation

Quotation shall remain valid for a period not less than 45 days after the deadline date specified for submission.

7. Opening of Quotations

Quotations will be opened in the presence of bidders or their representatives who choose to attend on the date and time and at the place specified in the letter of invitation.

8. Information relating to evaluation of quotations and recommendations for the award of contract shall not be disclosed to bidders or any other persons not officially concerned with the process until the award to the successful bidder is announced.

9. Evaluation of Quotations

The Employer will evaluate and compare the quotations determined to be substantially responsive i.e. which

- (a) meet the qualification criteria specified in clause 3 above;
- (b) are properly signed ; and
- (c) conform to the terms and conditions, specifications and drawings without material deviations.

10. Award of contract

The Employer will award the contract to the bidder whose quotation has been determined to be substantially responsive and who has offered the lowest evaluated quotation price and who meets the specified qualification criteria.

10.1 Notwithstanding the above, the Employer reserves the right to accept or reject any quotations and to cancel the bidding process and reject all quotations at any time prior to the award of contract.

10.2 The bidder whose bid is accepted will be notified of the award of contract by the Employer prior to expiration of the quotation validity period.

11. Performance Security

Within 15 days of receiving letter of acceptance, the successful bidder shall deliver to the Director, Department of Air Transport, the performance security (either a bank guarantee or a bank draft in favour of the Employer) for an amount equivalent of 10 % of the contract price. The Performance Security shall be valid till the expiry of the period of maintenance of the work, specified in clause 12. Failure of the successful Bidder to furnish performance security and signing the agreement within the period stipulated shall constitute sufficient grounds for annulment of award and debarring the bidder for a period of one year, in which case the Employer may make the award to the next lowest evaluated bidder or seek quotations afresh.

12. Period of Maintenance:

The “Period of Maintenance” for the work is six months from the date of taking over possession or one full monsoon season whichever occurs later. During the period of maintenance, the contractor will be responsible for rectifying any defects in construction free of cost to the Employer.

- 13.** Purchase of all construction materials including cement and steel as per the specifications (ISI/BSB certification marked goods wherever available) shall be the responsibility of the contractor.

.....

SECTION - B

- 1. Format for Qualification Information.**
- 2. Format for Submission of Quotation.**
- 3. Format of Letter of Acceptance.**

QUALIFICATION INFORMATION

1 For Individual Bidders

1.1 Principal place of business: _____

Power of attorney of signatory of Quotation.
[Attach copy]

1.2 Total value of Civil Engineering construction work performed in the last three years (in Nu. Million)

	20	
	20	
	20	

1.3 Work performed as prime contractor (in the same name) on works of a similar nature over the last three years.

Project Name	Name of Employer	Description of work	Contract No.	Value of contract (Nu. M)	Date of issue of work order	Stipulated period of completion	Actual date of completion	Remarks explaining reasons for delay and work completed

Existing commitments and on-going works:

Description of Work	Place & State	Contract No. & Date	Value of Contract (Nu. M)	Stipulated period of completion	Value of works* remaining to be completed (Nu. M)	Anticipated date of completion
(1)	(2)	(3)	(4)	(5)	(6)	(7)

* Enclose a certificate from Engineer concerned.

1.4 Proposed subcontracts and firms involved: Not applicable

Sections of the works	Value of Sub-contract	Sub-contractor (name & address)	Experience in similar work
*	*	*	*
*	*	*	*
*	*	*	*
	*	*	

1.5 Evidence of access to financial resources to meet the requirements of working capital: cash in hand, lines of credit, etc. List them below and attach copies of support documents. **Not applicable**

1.6 Name, address, and telephone, telex, and fax numbers of the Bidders' bankers who may provide references if contacted by the Employer.

1.7 Information on litigation history in which the Bidder is involved.

Other party(ies)	Employer	Cause of dispute	Amount involved	Remarks showing present status

QUOTATION

Description of the Works: **Construction of landing pad and marking and supply and installation of windsock at Samtse**

To:

Subject : Construction of
.....

Reference : DoAT/ADD/2019-20/932

Sir,

We offer to execute the Works described in your letter referred to above in accordance with the Conditions of Contract enclosed therewith at percentage above / below the estimated rates, i.e., for a total Contract Price of -

Nu. ** _____ [in figures]

Nu. _____ [in words].

This quotation and your written acceptance of it shall constitute a binding contract between us. We understand that you are not bound to accept the lowest or any quotation you receive.

We hereby certify that we have taken steps to ensure that no person acting for us or on our behalf will engage in bribery or collusive arrangements with the competitors.

We hereby confirm that this quotation is valid for 45 days as required in Clause 6 of the Instructions to Bidders.

We have not been debarred/removed from approved lists/(dealings suspended) by the Governments or by the World Bank.

Yours faithfully,

Authorized Signature : _____ Date: _____

Name & Title of Signatory : _____

Name of Bidder : _____

Address : _____

* To be filled in by the Employer before issue of the Letter of Invitation.

** To be filled in by the Bidder, together with his particulars and date of submission at the bottom of this Form.

**LETTER OF ACCEPTANCE
CUM NOTICE TO PROCEED WITH THE WORK**

(LETTERHEAD OF THE EMPLOYER)

Dated: _____

To: _____ [Name and address of the Contractor]

Dear Sirs,

This is to notify you that your quotation dated _____ for execution of the _____ for the contract price of Ngultrum _____ [amount in words and figures], is hereby accepted by us.

You are hereby requested to furnish performance security for an amount of Rs. _____ (equivalent to 10% of the contract price) within 15 days of the receipt of the letter. The Performance Security in the form of Bank guarantee or a Bank draft in favour of (Employer) shall be valid till the expiry of the period of maintenance i.e. upto _____. Failure to furnish the Performance Security will entail cancellation of the award of contract.

You are also requested to sign the agreement form and proceed with the work not later than _____ under the instructions of the Engineer, _____ and ensure its completion within the contract period.

With the issuance of this acceptance letter and your furnishing the Performance Security, contract for the above said work stands concluded.

Yours faithfully,

**Authorized Signature
Name and title of Signatory**

**Draft Agreement form for
Construction through National Shopping**

ARTICLES OF AGREEMENT

This deed of agreement is made in the form of agreement on _____ day _____ month _____ 199 ____, between the _____ (Employer) or his authorized representative (hereinafter referred to as the first party) and _____ (Name of the Contractor), S/O _____ resident of _____ (hereinafter referred to as the second party), to execute the work of construction of _____ (hereinafter referred to as works) on the following terms and conditions.

2. Cost of the Contract

The total cost of the works (hereinafter referred to as the “total cost”) is Nu. ____ as reflected in Annexure - 1.

3.1 Payments under its contract:

Payments to the second party for the construction work will be released by the first party in the following manner:-

On signing of agreement	:	10% of total cost
Completion of pavement works	:	1st RA Bill
Installation of windsock	:	2 nd RA Bill
Completion of markings and other finishing works	:	Final Bill

3.2 Payments at each stage will be made by the first party:

- (a) on the second party submitting an invoice for an equivalent amount ;
- (b) on certification of the invoice (except for the first installment) by the engineer nominated by the first party with respect to quality of works in the format in Annexure - 2; and
- (c) upon proper and justified utilization of at least 50 % of the previous installment and 100 % of any prior installment.

4. Notice by Contractor to Engineer

The second party, on the works reaching each stage of construction, issue a notice to the first party or the Engineer nominated by the first party (who is responsible for

supervising the contractor, administering the contract, certifying the payments due to the contractor, issuing and valuing variations to the contract, awarding extensions of time etc.), to visit the site for certification of stage completion. Within 15 days of the receipt of such notice, the first party or the engineer nominated by it, will ensure issue of stage completion certificate after due verification.

5. Completion time

The works should be completed in 60 days from the date of this Agreement. In exceptional circumstances, the time period stated in this clause may be extended in writing by mutual consent of both the parties.

6. If any of the compensation events mentioned below would prevent the work being completed by the intended completion date, the first party will decide on the intended completion date being extended by a suitable period:

- a) The first party does not give access to the site or a part thereof by the agreed period.
- b) The first party orders a delay or does not issue completed drawings, specifications or instructions for execution of the work on time.
- c) Ground conditions are substantially more adverse than could reasonably have been assumed before issue of letter of acceptance and from information provided to second party or from visual inspection of the site.
- d) Payments due to the second party are delayed without reason.
- e) Certification for stage completion of the work is delayed unreasonably.

7. Any willful delay on the part of the second party in completing the construction within the stipulated period will render him liable to pay liquidated damages. @ 0.05% of the initial contract price per day which will be deducted from payments due to him. The first party may cancel the contract and take recourse to such other action as deemed appropriate once the total amount of liquidated damages exceeds 2 % of the contract amount.

8. Duties and responsibilities of the first party

8.1 The first party shall be responsible for providing regular and frequent supervision and guidance to the second party for carrying out the works as per specifications. This will include written guidelines and regular site visit of the authorized personnel of the first party, for checking quality of material and construction to ensure that it is as per the norms.

- 8.2** The first party shall supply 3 sets of drawings, specifications and guidelines to the second party for the proposed works.
- 8.3** Possession of the site will be handed over to the second party within 10 days of signing of the agreement.
- 8.4** The Engineer or such other person as may be authorized by the first party shall hold meeting once in a month where the second party or his representative at site will submit the latest information including progress report and difficulties if any, in the execution of the work. The whole team may jointly inspect the site on a particular day to take stock of activities.
- 8.5** The Engineer shall record his observations/instructions at the time of his site visit in a site register maintained by the second party. The second party will carry out the instructions and promptly rectify any deviations pointed out by the engineer. If the deviations are not rectified, within the time specified in the Engineer's notice, the first party as well as the engineer nominated by it, may instruct stoppage or suspension of the construction. It shall thereupon be open to the first party or the engineer to have the deviations rectified at the cost of the second party.

9. Duties and responsibilities of the second party

9.1 The second party shall:

- a) take up the works and arrange for its completion within the time period stipulated in clause 5;
- b) employ suitable skilled persons to carry out the works ;
- c) regularly supervise and monitor the progress of work ;
- d) abide by the technical suggestions/direction of supervisory personnel including engineers etc. regarding building construction ;
- e) be responsible for bringing any discrepancy to the notice of the representative of the first party and seek necessary clarification ;
- f) ensure that the work is carried out in accordance with specifications, drawings and within the total of the contract amount without any cost escalation ;
- g) keep the first party informed about the progress of work ;
- h) be responsible for all security and watch and ward arrangements at site till handing over of the building to the first party ; and
- i) maintain necessary insurance against loss of materials/cash, etc. or workman disability compensation claims of the personnel deployed on the works as well as third party claims.

- f) Pay all duties, taxes and other levies payable by construction agencies as per law under the contract (First party will effect deduction from running bills in respect of such taxes as may be imposed under the law).

10. Variations / Extra Items

The works shall be carried out by the second party in accordance with the approved drawings and specifications. However, if, on account of site conditions or any other factors, variations are considered necessary, the following procedure shall be followed:-

- a) The second party shall provide the Engineer with a quotation for carrying out the Variation when requested to do so by the Engineer. The Engineer shall assess the quotation, which shall be given within seven days of the request before the Variation is ordered.
- b) If the quotation given by the second party is unreasonable, the Engineer may order the Variation and make a change to the Contract Price which shall be based on Engineer's own forecast of the effects of the Variation on the Contractor's costs.
- c) The second party shall not be entitled to additional payment for costs which could have been avoided by giving early warning.

11. Securities

The Performance Security shall be provided to the Employer no later than the date specified in the Letter of Acceptance and shall be issued in an amount and form and by a bank or surety acceptable to the Employer. The Performance Security shall be valid until a date 28 days from the date of issue of the Certificate of Completion in the case of a Bank Guarantee.

12. Termination

12.1 The Employer may terminate the Contract if the other party causes a fundamental breach of the Contract.

12.2 Fundamental breaches of Contract include, but shall not be limited to the following:

- (a) the contractor stops work for 28 days and the stoppage has not been authorized by the Engineer;
- (b) the Contractor has become bankrupt or goes into liquidation other than for a reconstruction or amalgamation;
- (c) the Engineer gives Notice that failure to correct a particular Defect is a fundamental breach of Contract and the Contractor fails to correct it within a reasonable period of time determined by the Engineer;

(d) the Contractor does not maintain a security which is required;

12.3 Notwithstanding the above, the Employer may terminate the Contract for convenience.

12.4 If the Contract is terminated the Contractor shall stop work immediately, make the Site safe and secure and leave the Site as soon as reasonably possible.

13. Payment upon Termination

13.1 If the Contract is terminated because of a fundamental breach of Contract by the Contractor, the Engineer shall issue a certificate for the value of the work done less advance payments received up to the date of the issue of the certificate, less other recoveries due in terms of the contract, less taxes due to be deducted at source as per applicable law.

13.2 If the Contract is terminated at the Employer's convenience, the Engineer shall issue a certificate for the value of the work done, the reasonable cost of removal of Equipment, repatriation of the Contractor's personnel employed solely on the Works, and the Contractor's costs of protecting and securing the Works and less advance payments received up to the date of the certificate, less other recoveries due in terms of the contract and less taxes due to be deducted at source as per applicable law.

14. Dispute settlement

If over the works, any dispute arises between the two parties, relating to any aspects of this Agreement, the parties shall first attempt to settle the dispute through mutual and amicable consultation.

In the event of agreement not being reached, the matter will be referred for arbitration by Bhutan Alternate Dispute Resolution Center, Thimphu. The decision of the Arbitrator shall be final and binding on both the parties.

BILL OF QUANTITIES

BSR Code	Description of activities	Qty	Unit	Rate	Amount
1. Site clearing					
CG0001	Clearing grass including removal of rubbish within 50m of site				
		676	sqm		
EW0195	Filling of trenches, sides of foundations etc. in layers <200mm using selected excavated earth, ramming etc. within lead 50 m & lift 1.5m				
		18	cum		
2 Landing pad					
EW0030	Earth work in excavation over areas, depth >300mm, width >1.5m, area >10 Sq.m on plan, including disposal of excavated earth within 50m lead and 1.5m lift & disposed soil to be neatly dressed: Ordinary soil				
		202.8	cum		
SM0072	Providing and laying Hand packed stone filling or soling				
		138.95	cum		
CW0002	Providing and laying in position plain cement concrete excluding the cost of centering and shuttering - All work upto plinth level. 1:1.5:3				
		105.15	cum		
RC0090	Providing & fixing centering and shuttering (formwork), including strutting, propping etc. and removal of formwork: Foundation and plinth etc.				
		84.2	sqm		
RC0105	Providing & filling or fixing in position in expansion joints: Blown bitumen				

		0.832	cum		
PT0010	Providing & applying one coat of primers: Cement primer				
		227.81	sqm		
PT0052	Providing and applying finishing coats: Vinyl plastic emulsion paint, for cement, masonry, plaster, two coats on new work				
		227.81	sqm		
3. Windsocks					
MR	Providing, fixing and installation of aviation windsock as per the sample available at operating helipads/airports. Bidders are requested to clearly understand the requirement of the windsock prior to quoting the price. The rate quoted will be considered to be including all the cost associated with the installation of the windsocks				
		1	set		
				Total	
Total in words:					

We agree to execute the works in accordance with the approved drawings and technical specifications atpercentage above/below the estimated rates, i.e., for a total contract price of Nu. (amount in figures) (Nu..... amount in words).

Signature of Contractor

Drawings

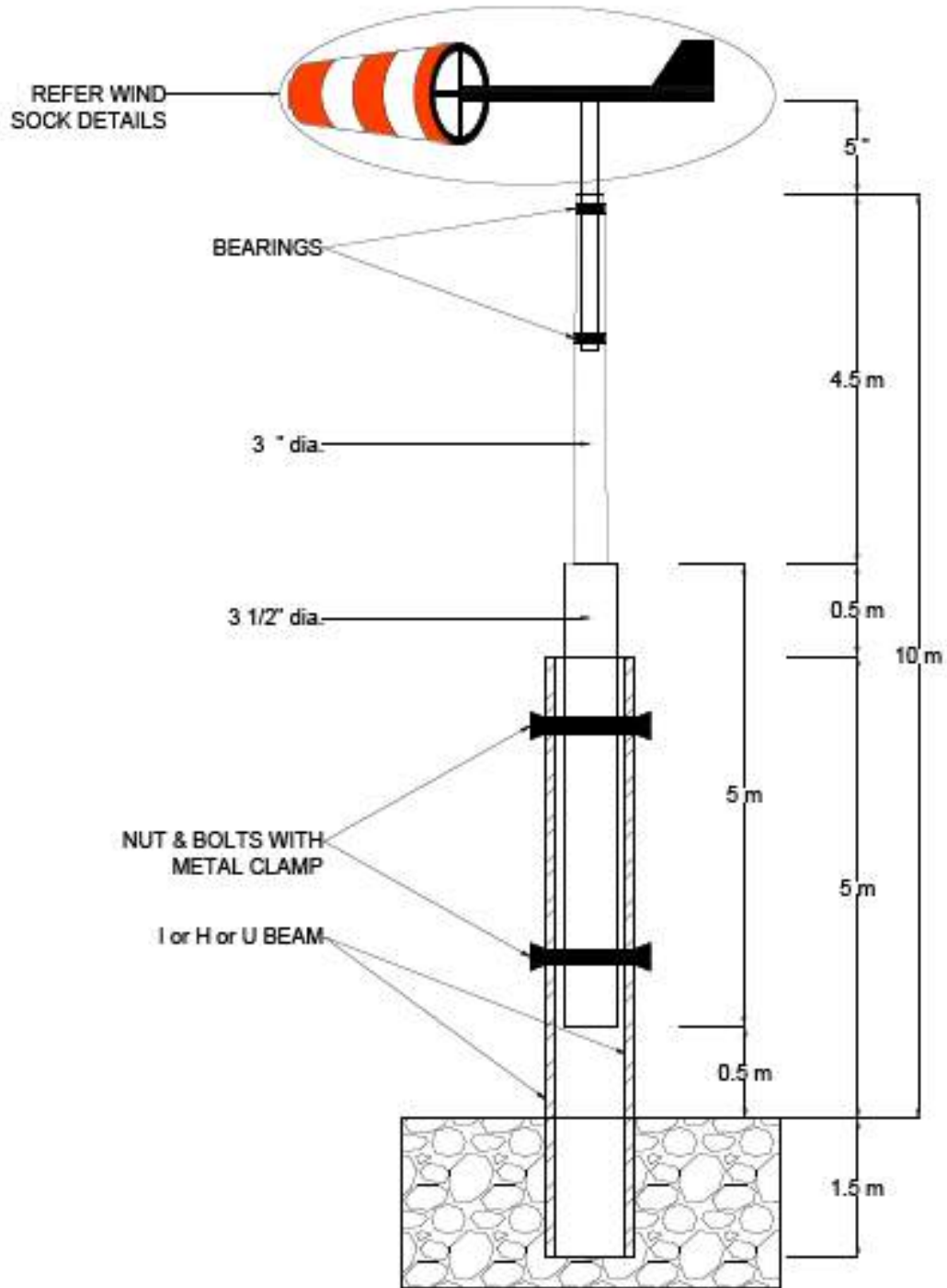

Windsock Elevation

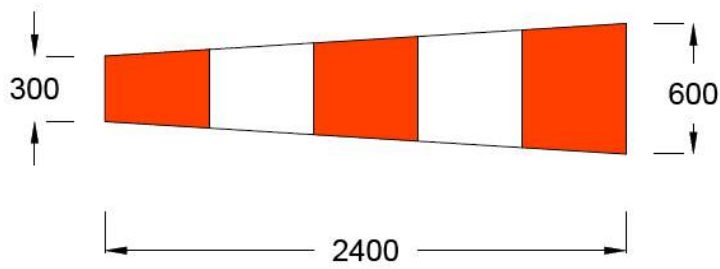

Windsock dimension

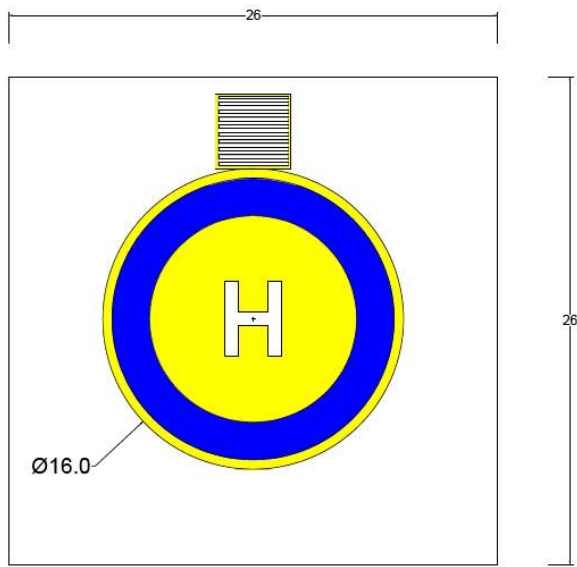

Marking plan

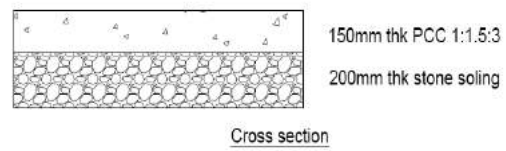

Cross section

Technical Specification

Specification for Building and Road Works published by Ministry of Works and Human Settlement, Royal Government of Bhutan will be followed.

<http://www.mowhs.gov.bt/wp-content/uploads/2014/08/SBRWCIVIL2017.pdf>

Format of certificate

Certified that the works upto ----- level in respect of construction of ----- at ----- have been executed in accordance with the approved drawing and technical specifications.

Signature
Name & Designation
(Official address)

Place :
Date :

Office seal

NR/ls May 8, 2008
m:\pdat\sbd\sbd-india-march 2008\w-5 (ns).doc
Corrected and reviewed by EJ on May 8, 2008